

INSTALLATION INSTRUCTIONS

Accessory	Application	Publications No.
BACKUP SENSOR	2009 ODYSSEY	All 40224
		Issue Date AUG 2008

PARTS LIST

Backup Sensor Attachment Kit P/N 08V67-SHJ-100B

Backup sensor control unit

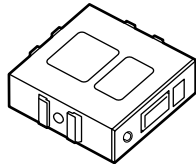

Buzzer

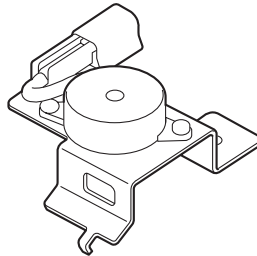

Switch

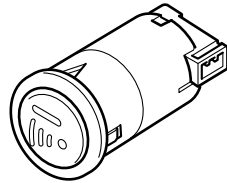

Backup sensor harness

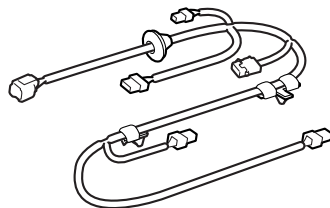

Backup sensor subharness

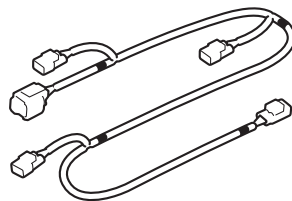

Control unit bracket

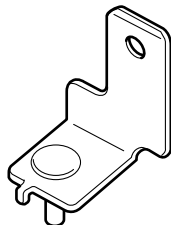

Right center sensor clip (Black)

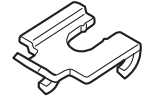

Left center sensor clip (White)

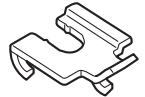

2 Corner sensor clips

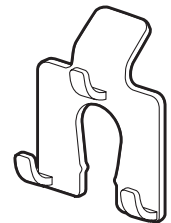

Switch bracket

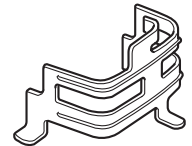

12 Wire ties

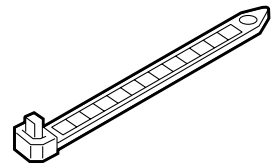

2 Wire ties with clip



Small wire tie

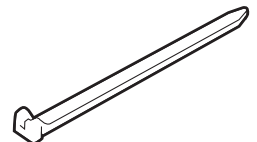

Harness clip



Blind nut



Washer-screw, 4 x 14 mm



Flange bolt, 6 x 12 mm



2 Flange nuts, 6 mm



Fuse label

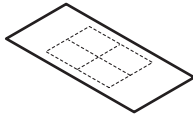

Urethane tape

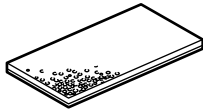

3 Harness tapes
(Silver)



Backup Sensor Kit

NOTE: Refer to Parts Information Bulletin (PIB) A07-007 for the proper color sensors.

Right center sensor

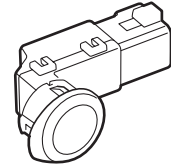

Left center sensor

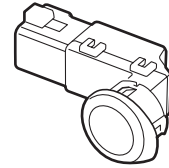

2 Corner sensors

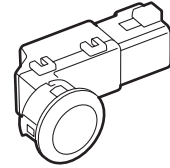

TOOL AND SUPPLIES REQUIRED

#2 Phillips screwdriver

Small flat-tip screwdriver

Felt-tip pen

10 mm Combination wrench

10 mm and 14 mm Socket

Pushpin

Ratchet

3 mm and 8 mm Drill bits

Eye protection (face shield, safety goggles, etc.)

File

Diagonal cutters

Scissors

Masking tape

Tape measure

Cardboard

Isopropyl alcohol

Shop towel

24 mm and 26 mm Holesaw (Holesaw set, T/N:
AKS052507)

Drill

Utility knife

Touch-up paint

Illustration of the Backup Sensors Installed on the Vehicle

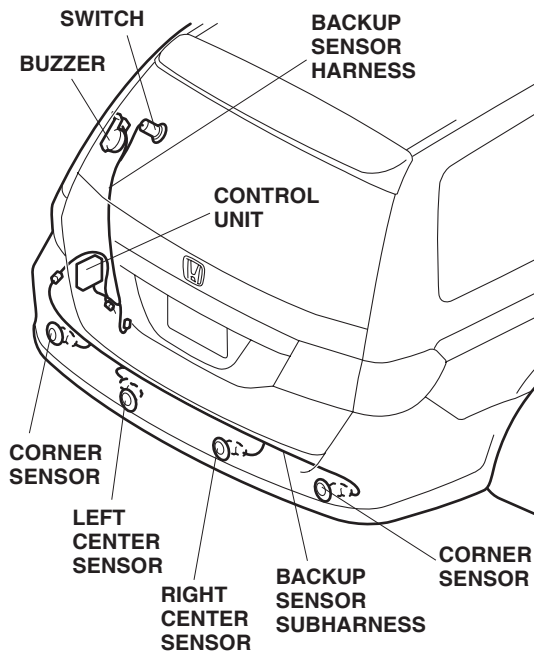

INSTALLATION

Customer Information: The information in this installation instruction is intended for use only by skilled technicians who have the proper tools, equipment, and training to correctly and safely add equipment to your vehicle. These procedures should not be attempted by “do-it-yourselfers.”

1. Make sure you have the anti-theft code for the radio, then write down the radio station presets.
2. Disconnect the negative cable from the battery.

3. Remove the rear bumper.

- Remove the two clips along the bottom of the bumper.
- Remove the four self-tapping screws from the bumper.
- Using a flat-tip screwdriver, pry out and remove the bumper bolt covers, then remove the four bumper bolts.
- With the help of an assistant, release the bumper from the fenderwell, and slide the bumper away from the vehicle.
- Set the bumper on a blanket.

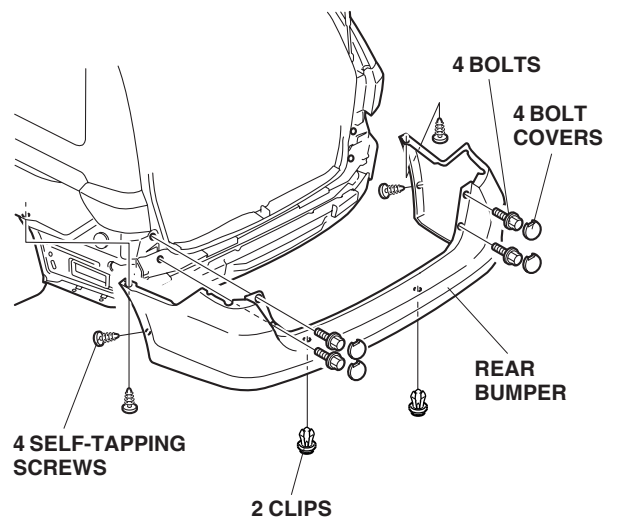

4. Pull away the weatherstrip from the driver's sliding door sill trim. Remove the driver's sliding door sill trim (five clips).

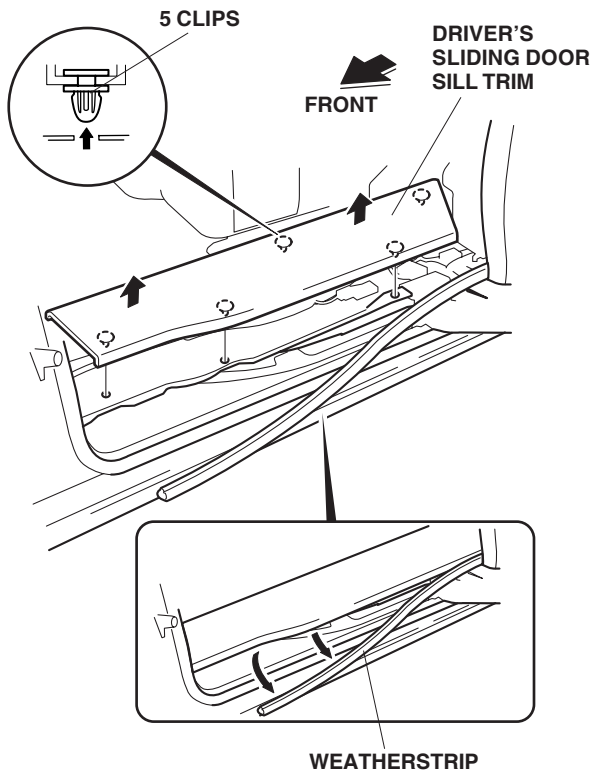

5. Pull away the weatherstrip from the rear trim panel. Remove the rear trim panel (10 clips and 2 screws).

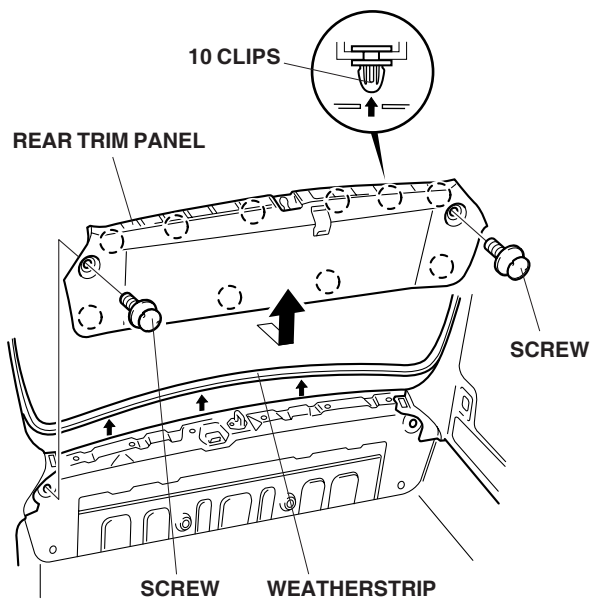

6. Fold down the third-row seat, and remove the spare tire cover (17 tabs).

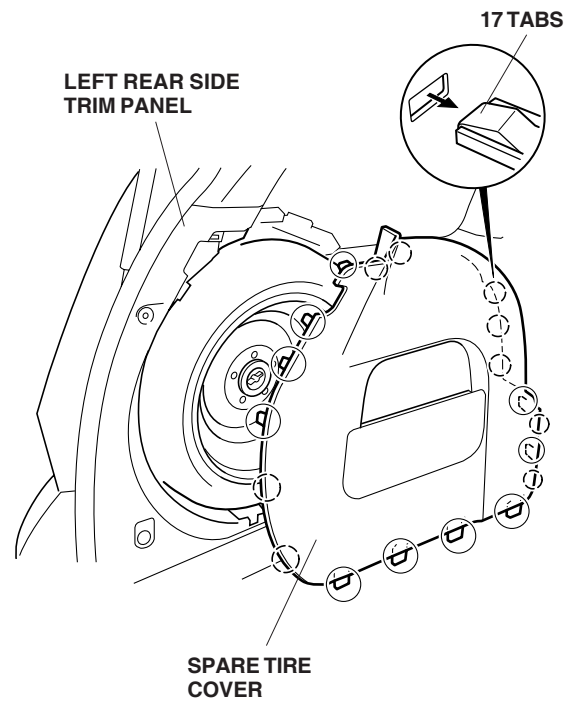

7. Remove the anchor bolt and the anchor bolt cover, and take out the spare tire.

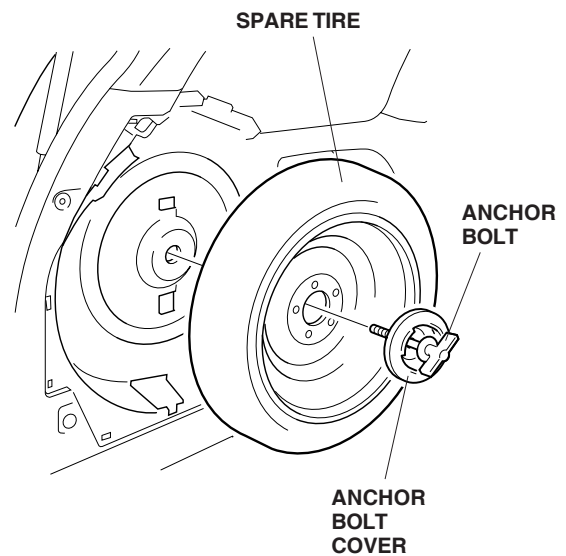

- Remove the jack cover (two tabs).

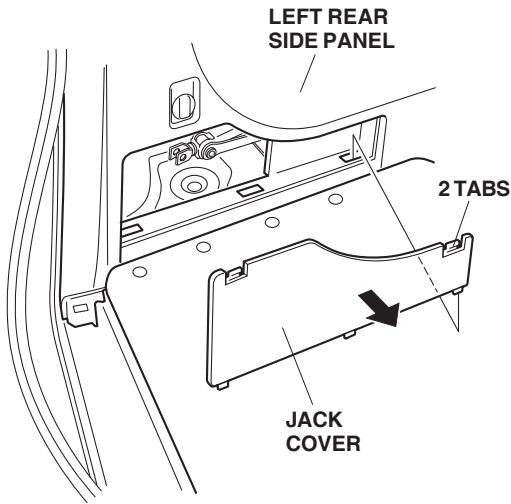

- Remove the left second-row seat belt upper anchor cover (two tabs). Remove the left second-row seat belt upper anchor bolt.

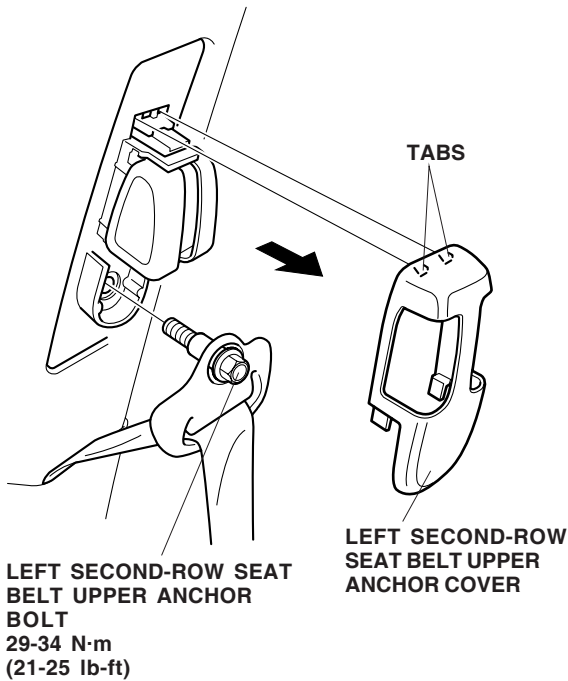

- Pull away the weatherstrip from the left quarter pillar trim. Remove the left quarter pillar trim (two tabs and side curtain airbag clip).

With SRS System Shown

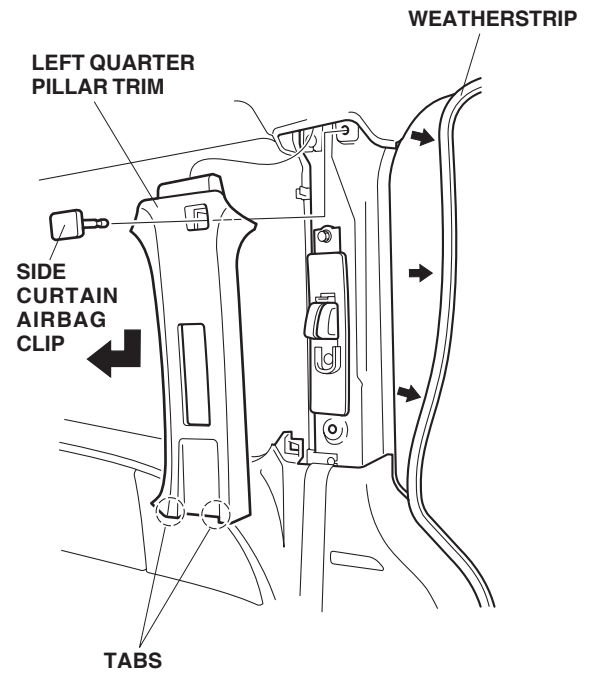

- Remove the left rear side trim panel:

- Remove the third-row seat rail cover (four clips).

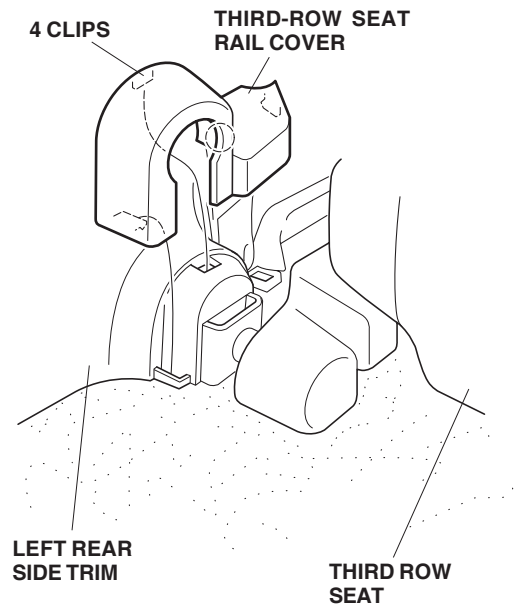

- Pull away the weatherstrip from the left rear side trim panel.
- Remove the second-row seat belt lower anchor bolt.
- Gently pull the panel towards you to release the eight clips and four retaining clips, release the third-row seat belt through the slit in the panel, disconnect the rear accessory socket connector, and disconnect two vehicle connectors.

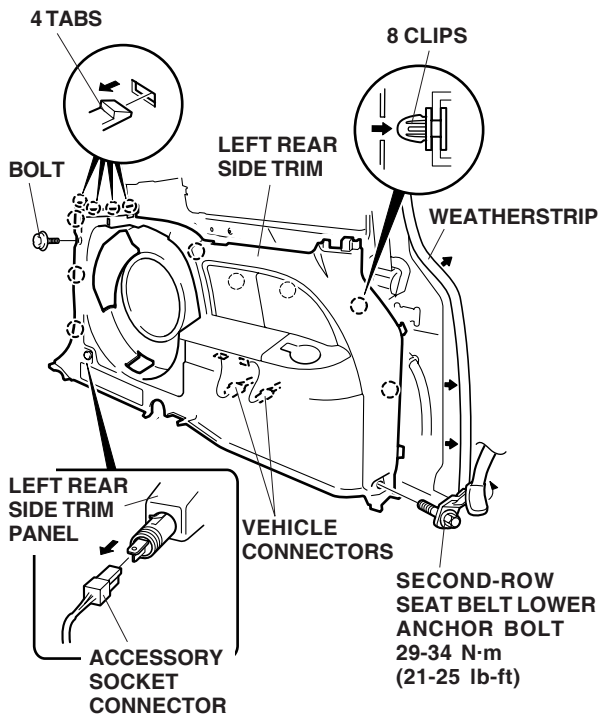

12. Remove the left rear pillar trim (one cover, one bolt, one clip, and two tabs).

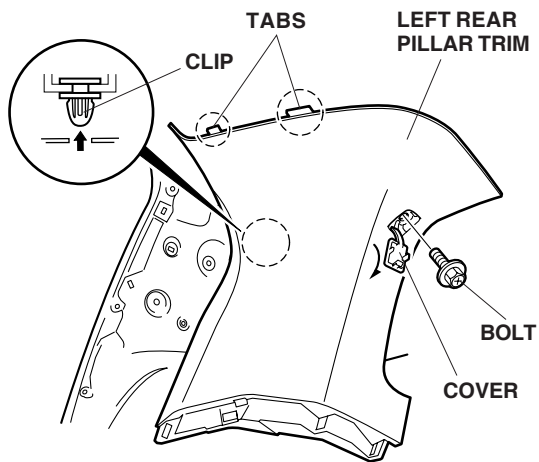

13. Remove the two self-tapping screws, disengage the retaining tab, and pull out the power door control unit. Move the control unit out of the way.

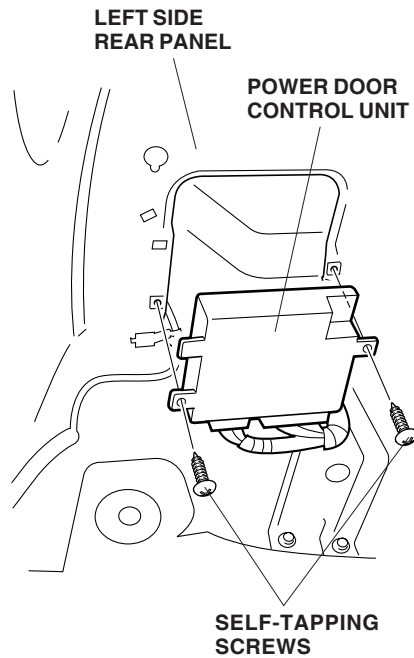

14. While wearing eye protection, drill the left rear body panel using an 8 mm drill bit.

- To prevent drilling through the vehicle panel, wrap masking tape around the drill bit as shown.
- After drilling, remove any burrs at the edges of the hole you made using a file, and apply touch-up paint to the edges. Allow the touch-up paint to dry thoroughly.

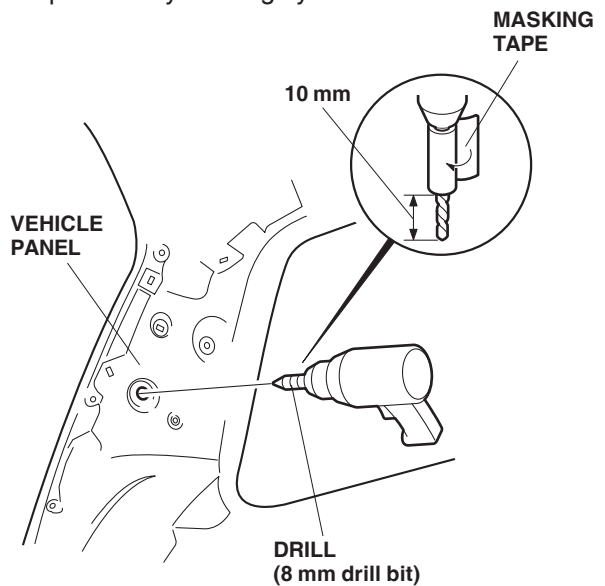

- Install the blind nut into the 8 mm hole you drilled in step 14. Attach the buzzer to the vehicle panel using the 4 x 14 mm washer-screw. If equipped with a vehicle harness, disengage the vehicle clip from the vehicle panel. Remove the tape and the vehicle clip. Attach the harness clip to the vehicle harness with the tape as shown. Secure the buzzer to the vehicle clip before installing it to the vehicle panel.

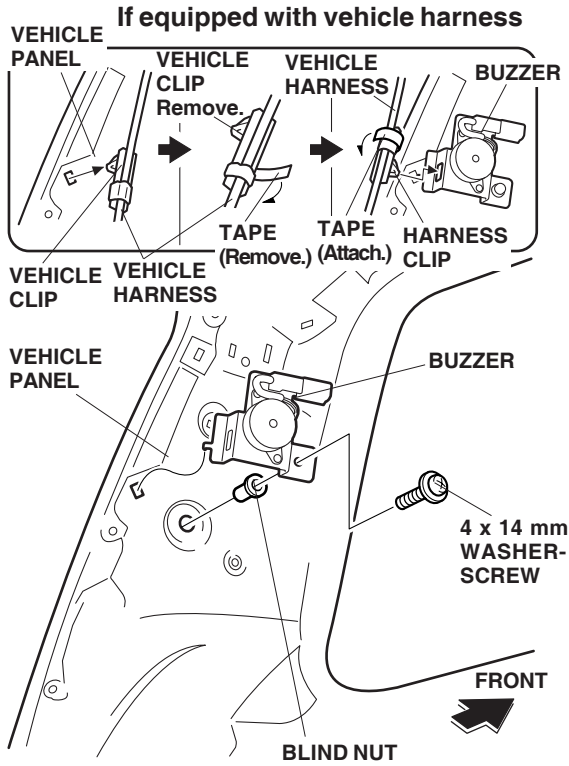

Routing the Backup Sensor Harness

- From the outside of the vehicle, remove the vehicle grommet. Pass the backup sensor harness through the hole where the vehicle grommet has been removed. Insert the grommet on the backup sensor harness in the hole.

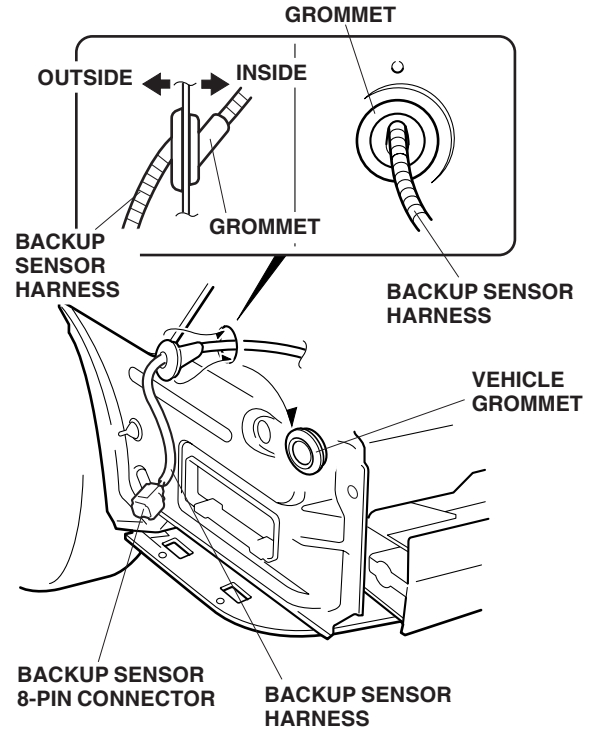

17. Install the 2 A fuse label to the fuse case.

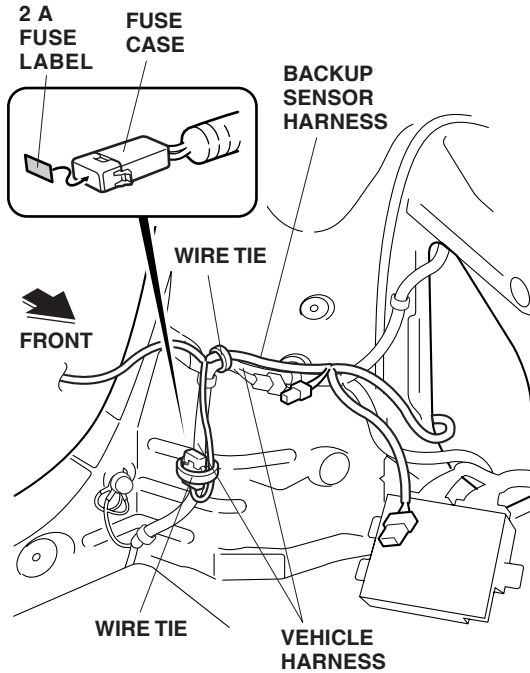

18. Route the backup sensor harness along the vehicle harness, and secure the fuse case to the vehicle harness with a wire tie.

19. Secure the backup sensor harness to the vehicle harness with a wire tie.

20. Remove the blue tape from the backup sensor harness. Connect the backup sensor harness 2-pin connector to the vehicle harness 2-pin connector.

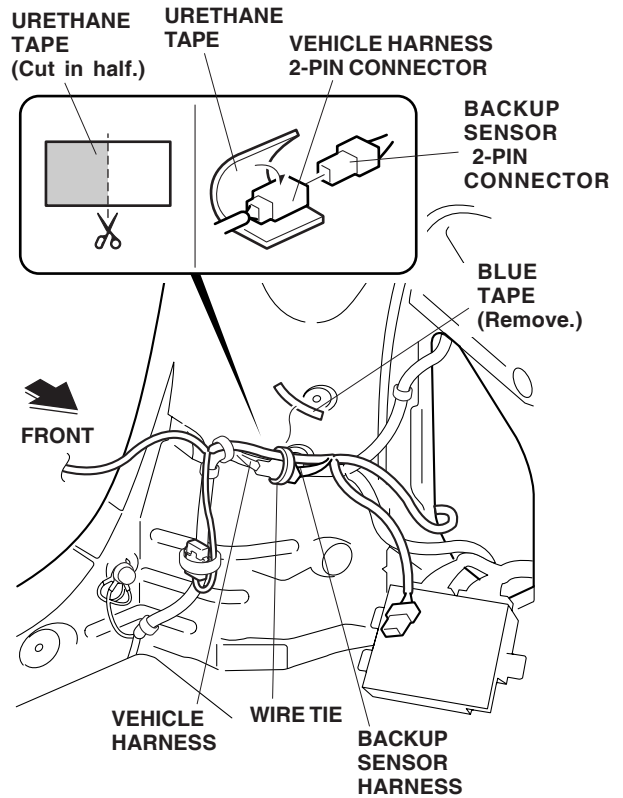

21. Cut a urethane tape in half, and wrap the connector with the half. Secure the connector to the vehicle harness with a wire tie.

22. Insert the control unit bracket, and connect the backup sensor 14-pin connector to the backup sensor control unit.

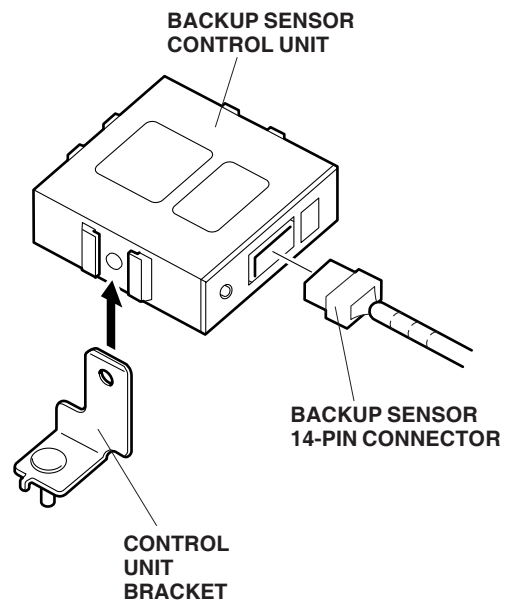

23. Attach the backup sensor control unit to the vehicle panel, and secure the control unit bracket with a 6 mm flange nut.

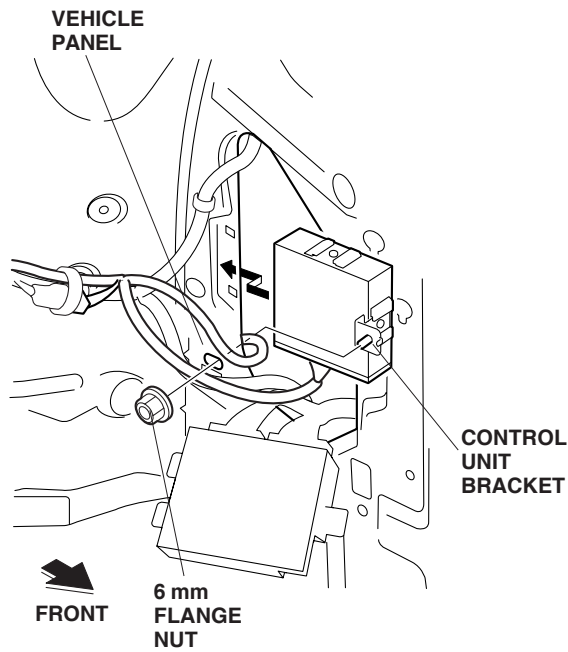

24. Secure the backup sensor to the vehicle harness with one wire tie.

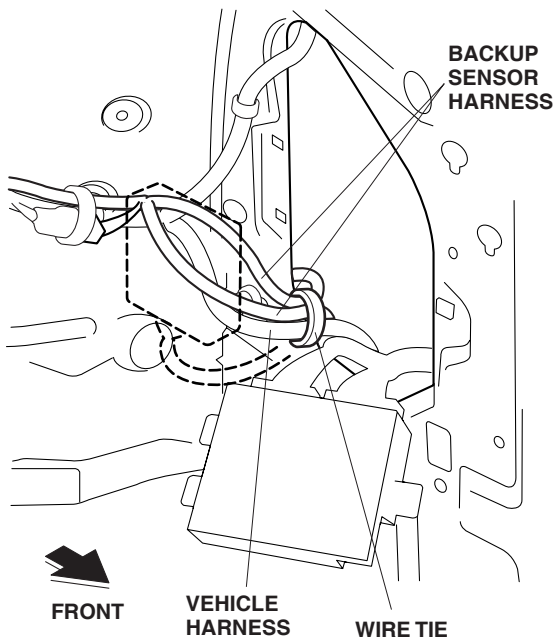

25. If not equipped with a vehicle harness, connect the backup sensor harness to the buzzer and secure the clip on the backup sensor harness to the vehicle panel.

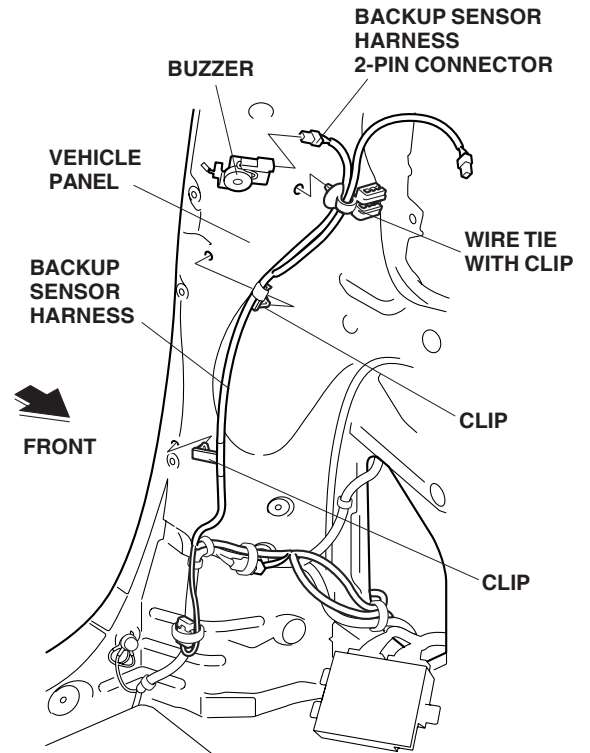

26. Install a wire tie with clip to the backup sensor harness, and secure the clip to the vehicle panel.

27. If equipped with a vehicle harness, remove the tape and release the clip from the backup sensor harness. Connect the backup sensor harness 2-pin connector to the buzzer.

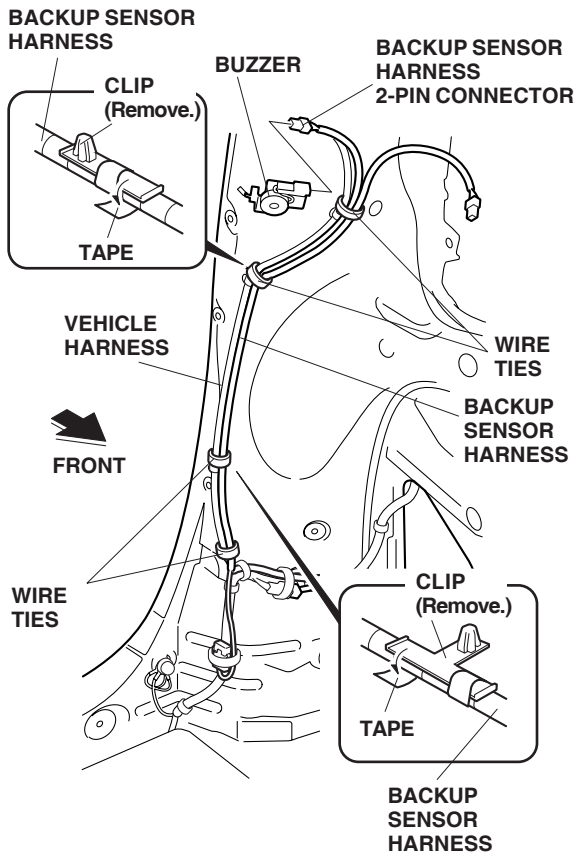

28. Secure the backup sensor harness to the vehicle panel with four wire ties.

29. Route the backup sensor harness toward the upper part of the vehicle, and secure the backup sensor harness to the vehicle panel with one wire with clip. If equipped with a vehicle harness, secure the backup sensor harness to the vehicle panel with one wire tie.

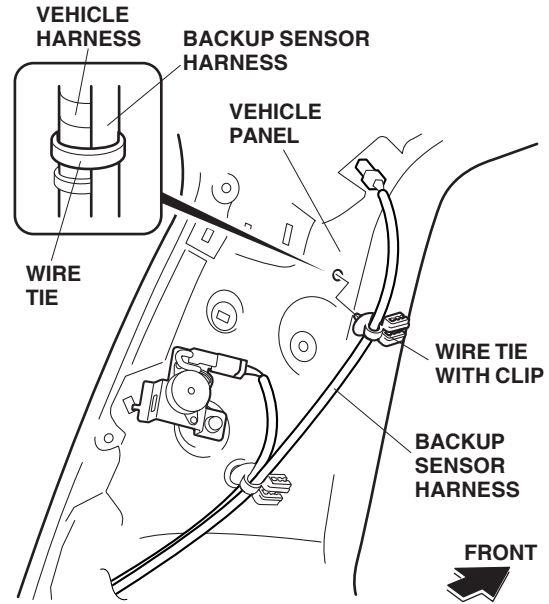

30. Secure the backup sensor 8-pin connector to the vehicle panel.

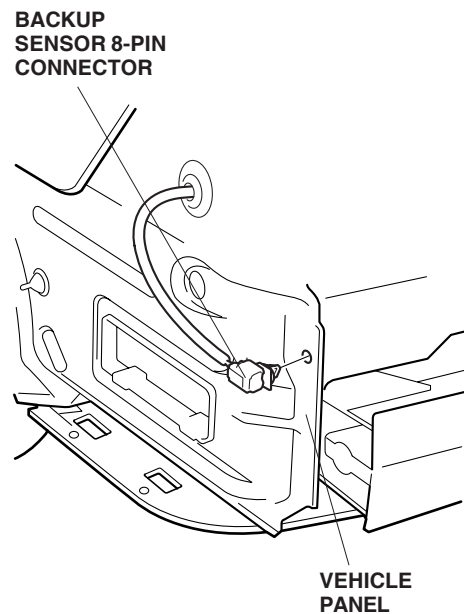

Installing the Switch

31. On the inside of the left rear pillar trim, measure from the inside of the ribs, and mark the pillar trim at the measurements shown. While wearing eye protection, drill a 3 mm hole at the marked position. Then drill with a 26 mm hole saw. Do not drill with a 1 inch drill bit. Remove any burrs with a file.

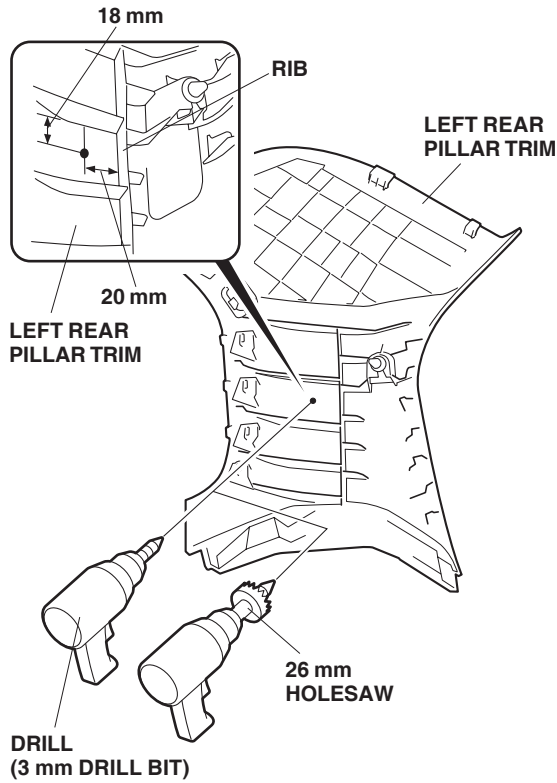

32. Insert the switch into the hole made in step 31, and install the switch bracket onto the switch as shown.

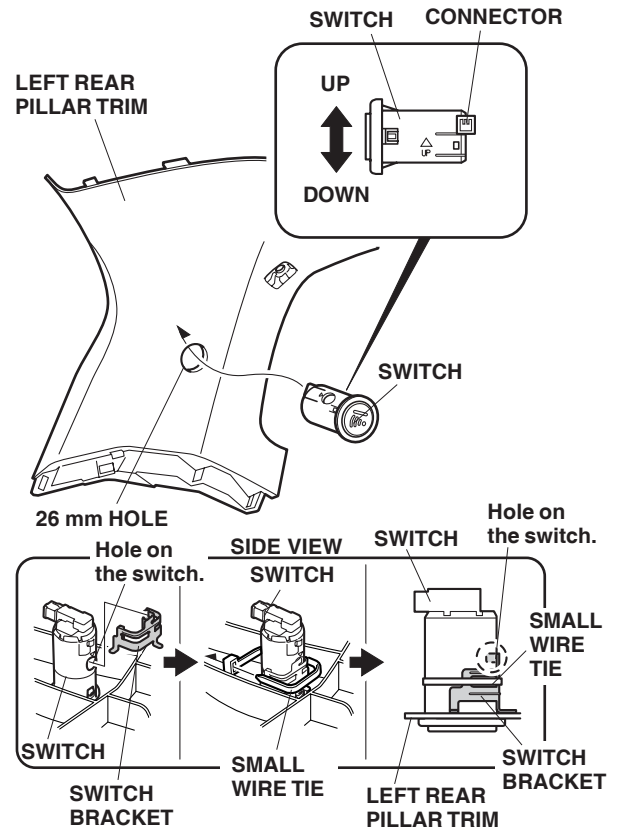

33. Secure the switch bracket to the switch with a small wire tie.

34. While holding the switch with your hand, plug the backup sensor harness 3-pin connector into the switch as shown.

For installation of the connector, check its vertical direction and connect securely so that no unreasonable force is used on the connector part of the switch.

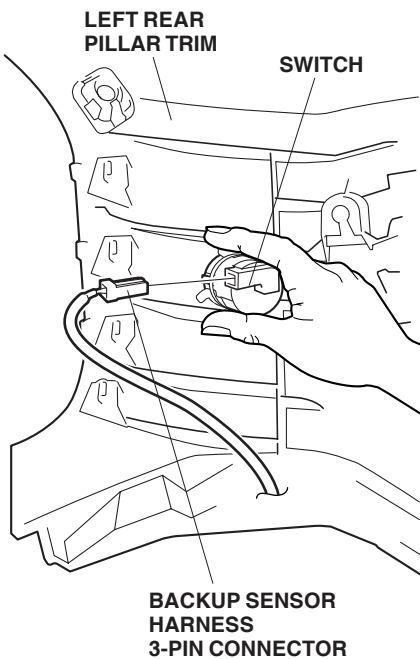

35. For the left rear pillar trim, insert the clip matching the upper tab and install the trim.

At the time of installation, take care that the switch does not come in contact with the left rear pillar trim.

NOTE: Tapping on the switch can damage the switch connector. Take care during installation of the trim.

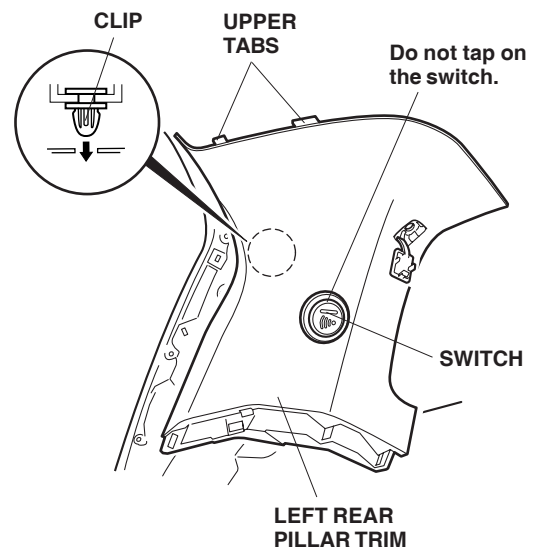

36. Reinstall the power door control unit that was removed in step 13.

Installing the Backup Sensor

37. On the inside of the rear bumper, locate and pierce the eight scribe marks on the rear bumper with a pushpin.

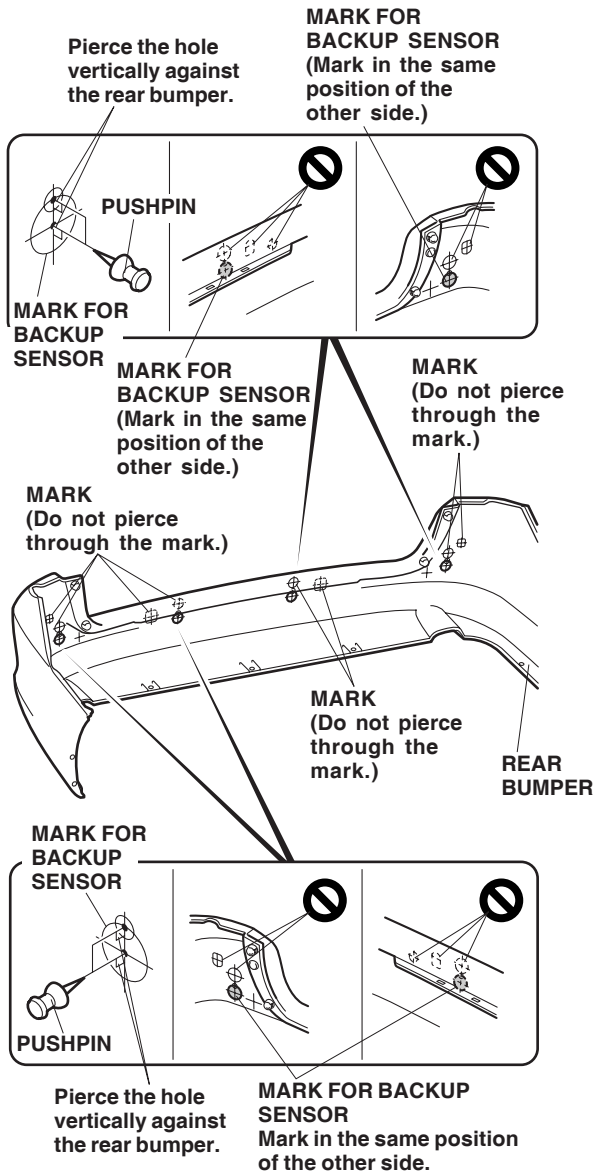

38. While wearing eye protection, drill 3 mm holes at the four pierced marks on the corner of the rear bumper from the outside. Widen the two lower holes with a 24 mm holesaw as shown. Remove any burrs.

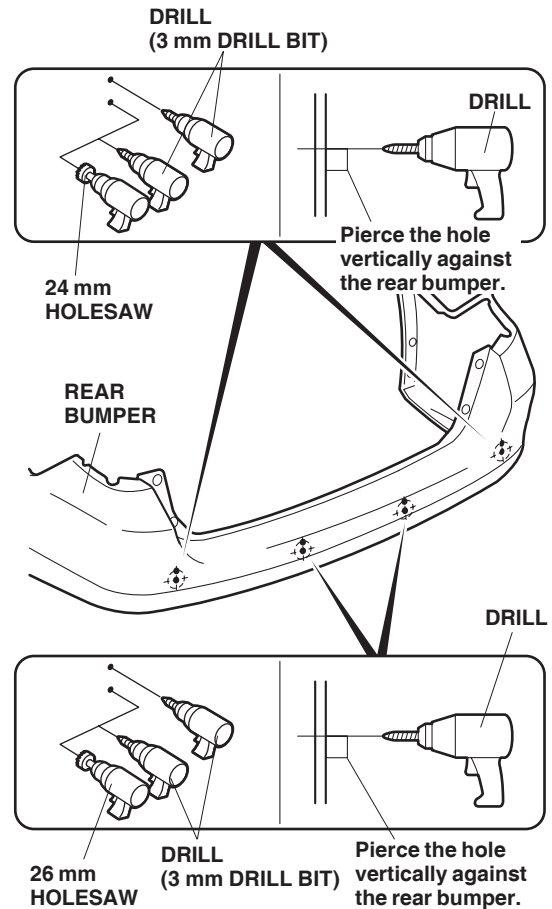

39. While wearing eye protection, drill 3 mm holes at the four pierced marks on the center of the rear bumper from the outside. Widen the two lower holes with a 26 mm holesaw as shown. Remove any burrs.

NOTE: The two center holes are larger than the two outer holes.

40. From the outside of the rear bumper, insert the right center sensor and left center sensor into the hole as shown.

NOTE: Make certain that the sensors are inserted into the correct holes.

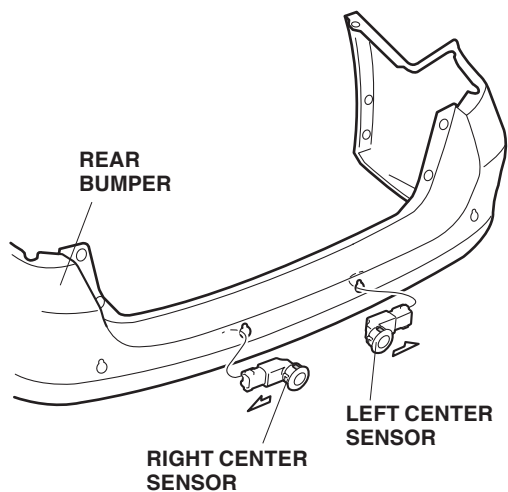

41. From the inside of the rear bumper, insert the right center sensor clip (black) and left center sensor clip (white) to the right center sensor and left center sensor.

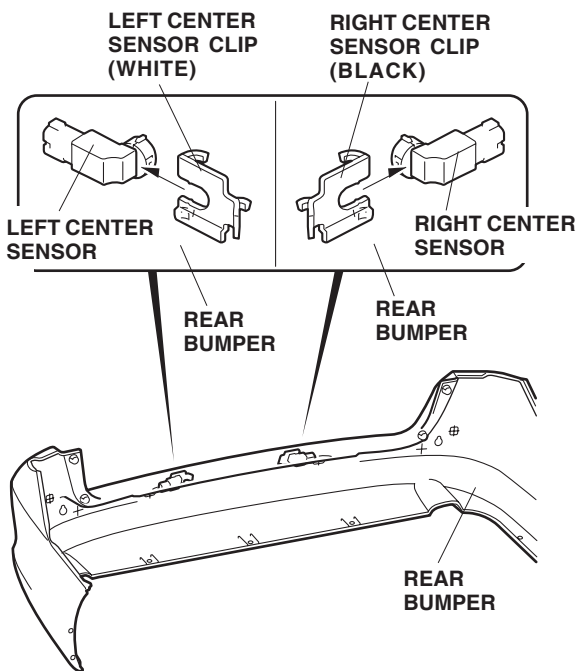

42. From the outside of the rear bumper, insert the two corner sensors into the holes as shown.

NOTE: Make certain that the sensors are inserted into the correct holes.

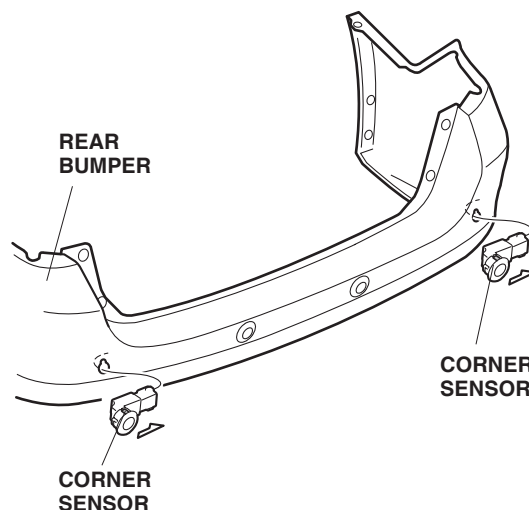

43. From the inside of the rear bumper, insert the two corner sensor clips to the two corner sensors.

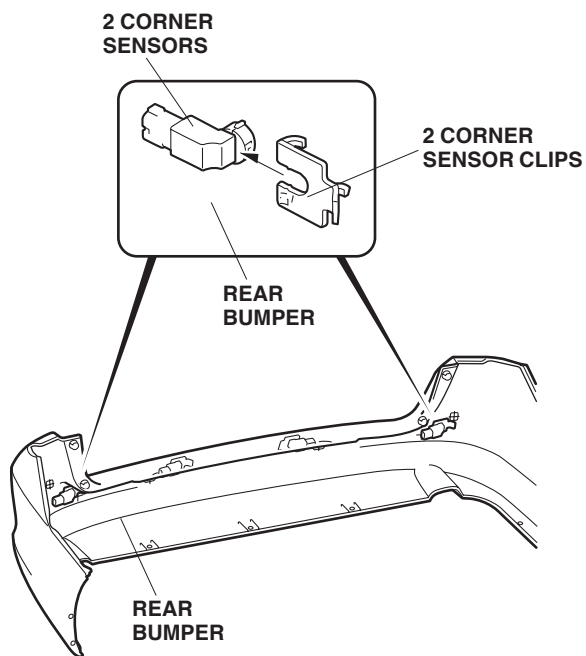

44. Connect the four backup sensor subharness 2-pin connectors to the right center sensor, left center sensor, and two corner sensors.

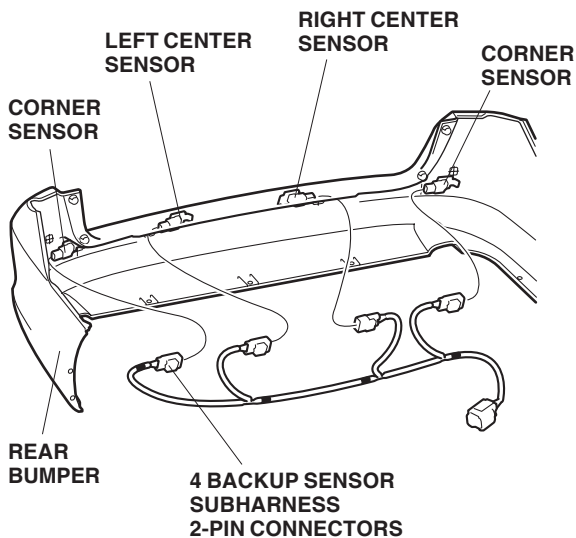

45. Secure the backup sensor subharness connector at the green tape with four wire ties.

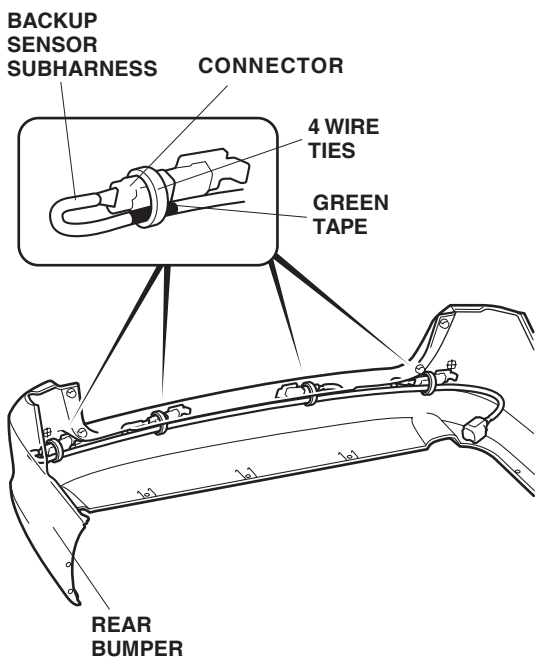

46. Using isopropyl alcohol on a shop towel, thoroughly clean the area where the harness tapes will attach. Secure the backup sensor subharness to the rear bumper with three harness tapes.

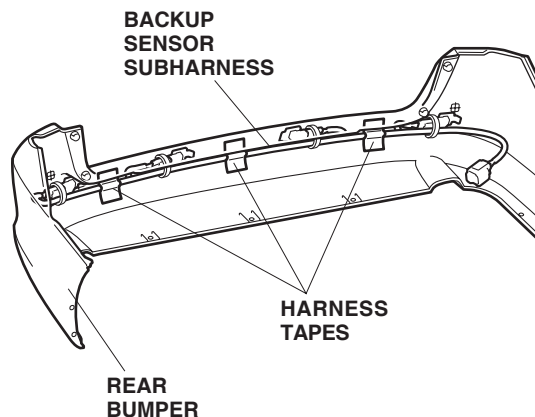

47. Bring the rear bumper to the vehicle, and connect the backup sensor subharness 8-pin connector to the backup sensor harness 8-pin connector.

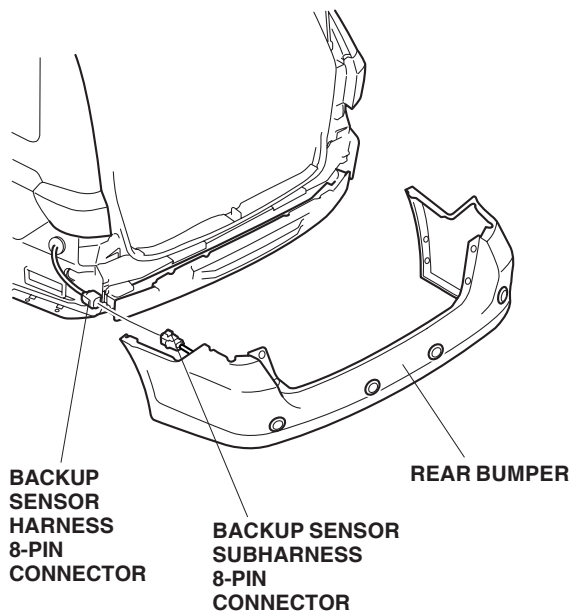

48. Install the rear bumper back onto the vehicle.

49. Check that all wire harnesses are routed properly and that all connectors are plugged in.
50. Reinstall all removed parts.
51. Reconnect the negative cable to the battery.
52. Enter the customer's radio anti-theft code, and reset the radio station presets.
53. Reset the clock.
54. Check the operation of the backup sensors as described in the backup sensor owner's manual supplied.

NOTE: When the battery is disconnected, the driver's window AUTO function is disabled.

- Start the engine. Push down on the driver's window switch until the window is fully open.
- Pull up on the driver's window switch to close the window completely, then hold the switch for 1 second or more.
- Lower and raise the driver's window to check operation of the driver's window AUTO function.