



INSTALLATION INSTRUCTIONS

Accessory
AM/FM CD TUNER

Application
**2009 CIVIC
2- AND 4-DOOR (DX)**

Publications No.
All 40108
Issue Date
AUG 2008

PARTS LIST

**Pocket Attachment Kit
P/N 08B60-SCV-101**

Pocket

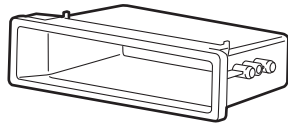

2 Self-tapping screws,
4 x 12 mm



**Antenna Subharness Kit
P/N 08B01-SNA-100**

Antenna subharness

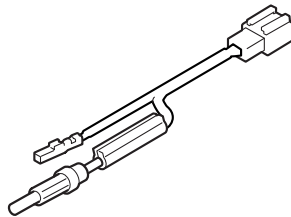

2 Wire ties

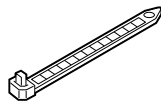

Cushion tape

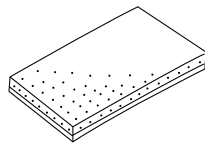

**AM/FM CD Tuner
P/N 08A02-4E1-100**

AM/FM CD tuner

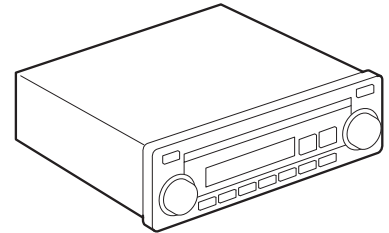

Accessory User's
Information Manual



4 Washer-screws,
5 x 8 mm



TOOLS REQUIRED

Phillips screwdriver
Flat-tip screwdriver
10 mm combination wrench
Shop towel
Scissors

INSTALLATION

Customer Information: The information in this installation instruction is intended for use only by skilled technicians who have the proper tools, equipment, and training to correctly and safely add equipment to your vehicle. These procedures should not be attempted by "do-it-yourselfers."

1. Disconnect the negative cable from the battery.

2. Remove the driver's dashboard lower cover (eight clips).

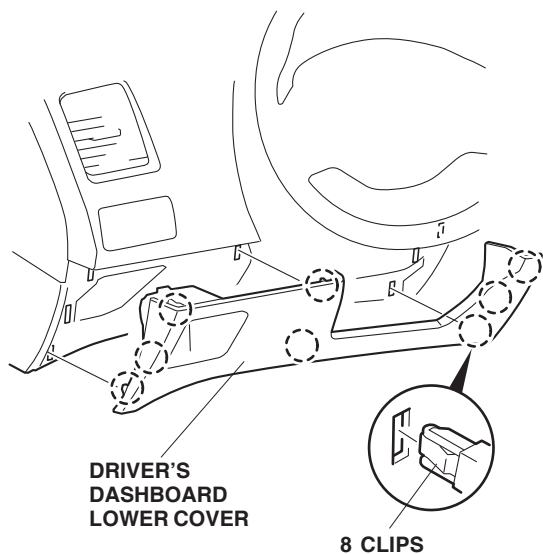

3. Remove the inside cover from the front console pocket (two tabs).

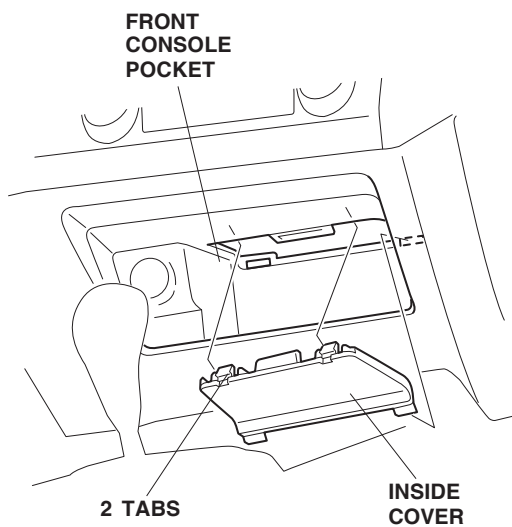

4. Lower the steering wheel tilt lever and pull the steering wheel toward you.

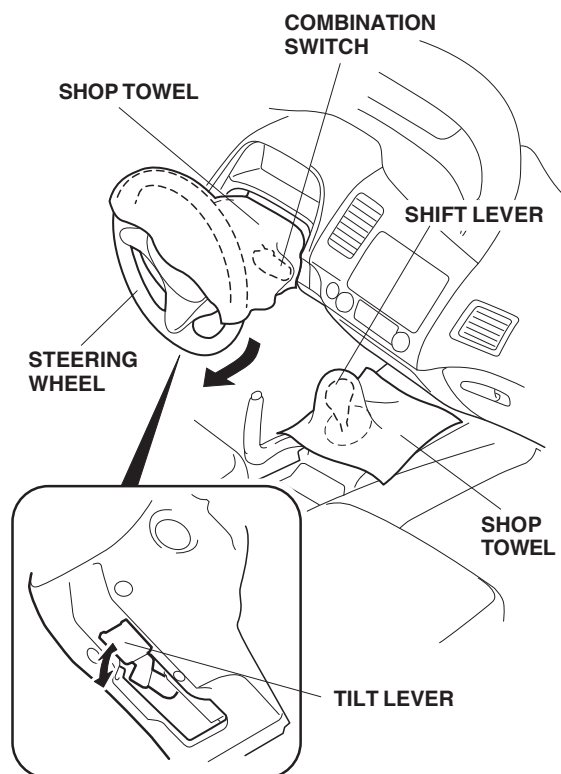

5. To protect the dashboard area, place a shop towel over the steering wheel and shift lever.

- Remove the instrument panel with the center panel (one screw, two bolts, nineteen retaining clips; unplug the vehicle connectors).

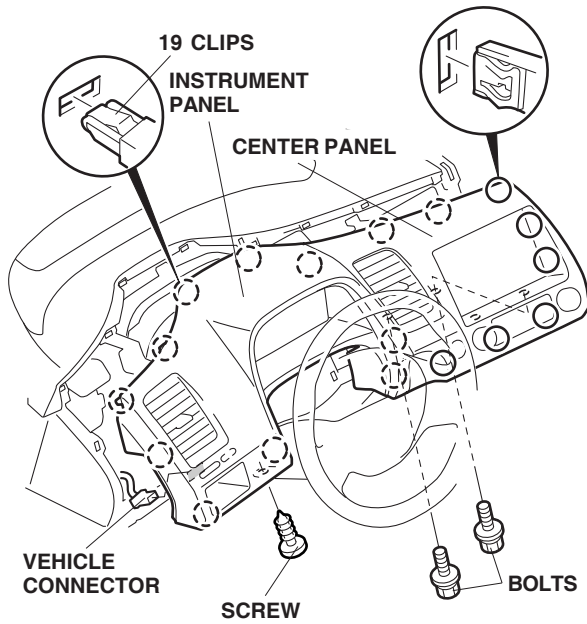

- Remove the center panel from the instrument panel by releasing the four clips.

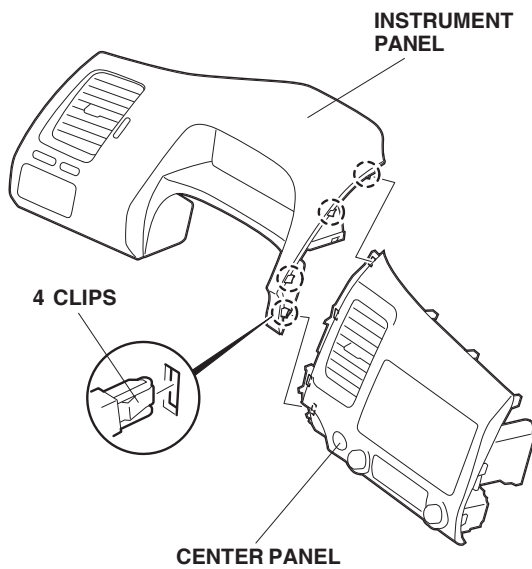

- Remove the audio cover from the center panel.

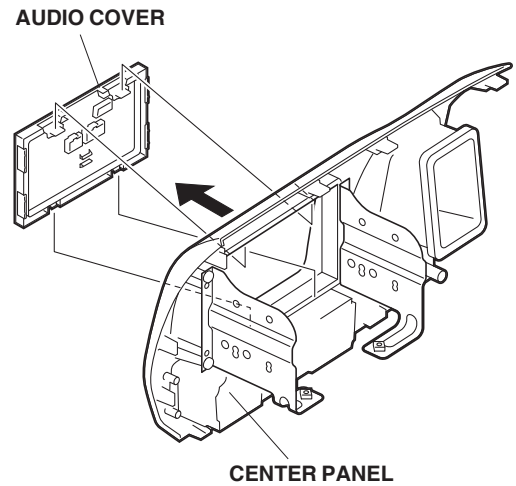

- Remove the air duct from the center panel (three screws).

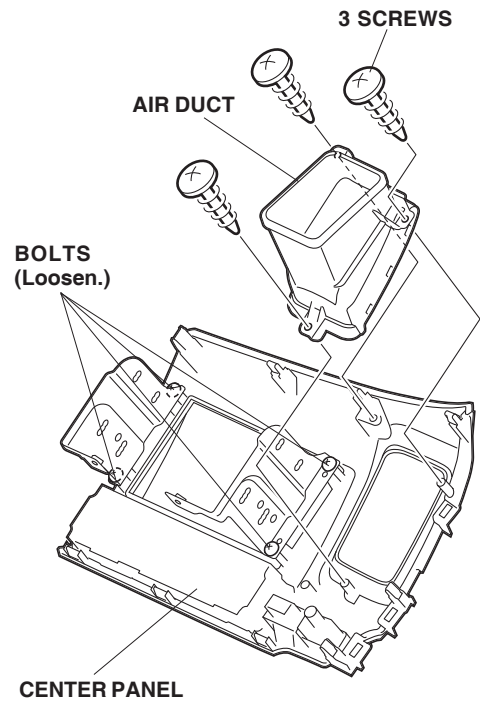

- Loosen the four bolts on the right and left audio brackets.

Installing the Pocket

- Using scissors, cut the cushion tape in half.

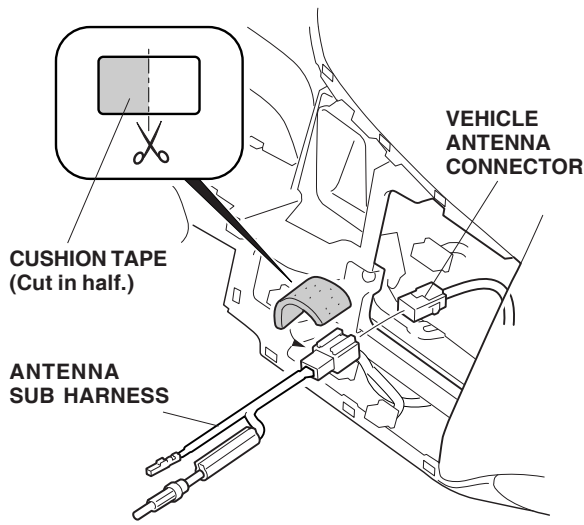

- Plug the antenna connector into the vehicle connector, then wrap the piece of cushion tape around the antenna connectors.
- Secure the antenna subharness to the vehicle harness on the steering hanger beam with a wire tie.

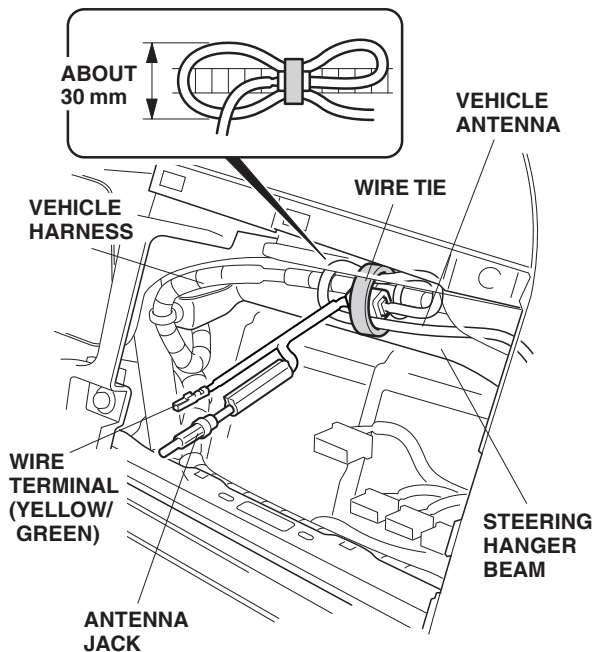

- Unlock the terminal lock on the vehicle 20-pin connector.

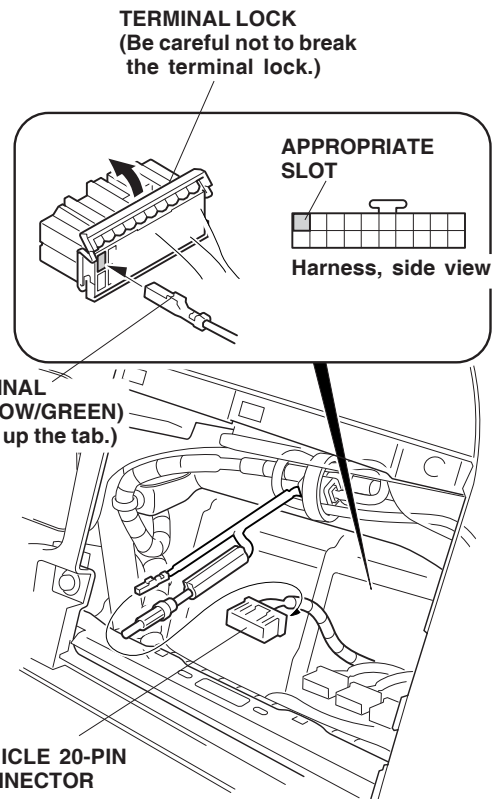

- Carefully push the wire terminal (yellow/green) of the antenna subharness into the appropriate slot of the vehicle 20-pin connector. Reattach the terminal lock.

16. Position the pocket into the center panel and install the two 4 x 12 mm self-tapping screws.

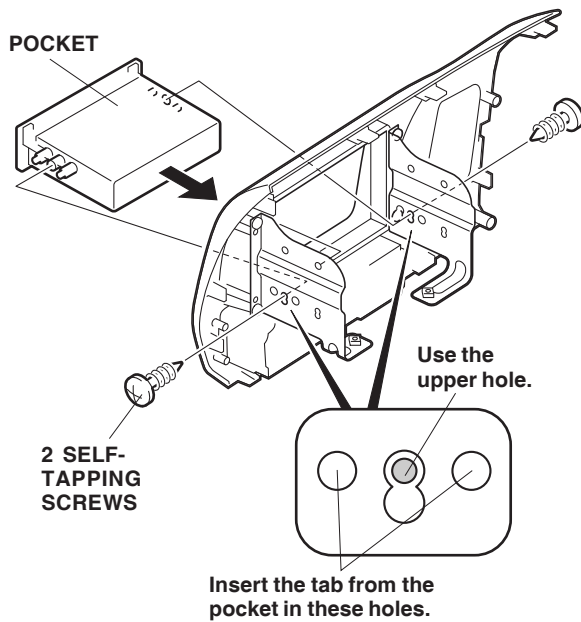

17. Fasten the two bolts on the left audio bracket you loosened in step 10.
18. Position the AM/FM CD tuner on the pocket and install the four 5 x 8 mm washer bolts.

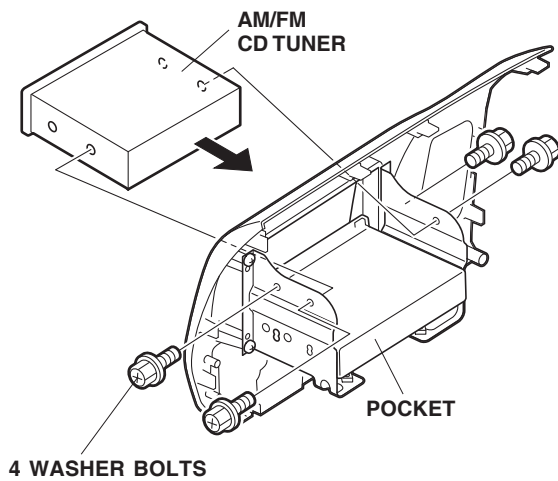

19. Fasten the two bolts on the right audio bracket you loosened in step 10, and reinstall the air duct.

20. Plug the vehicle 20-pin connector and antenna jack into the rear of the AM/FM CD tuner.

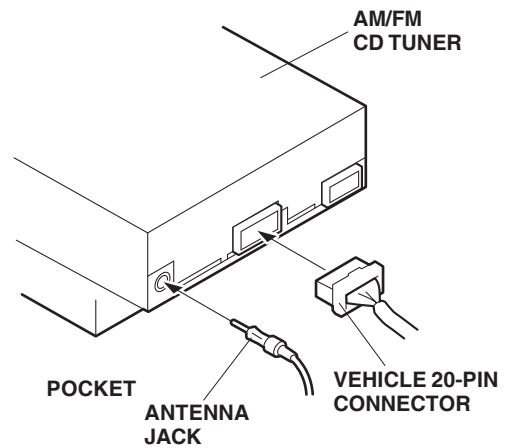

21. Connect the vehicle connectors to the center panel, and reinstall the center panel.

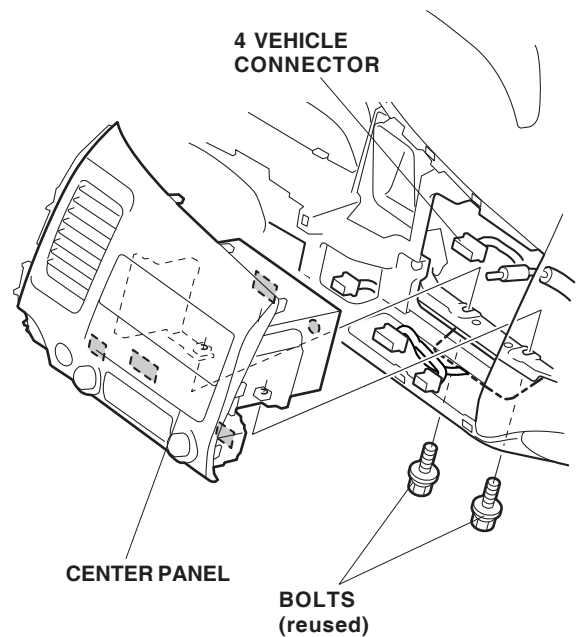

22. Check that all wire harnesses are routed properly and all connectors are plugged in.
23. Reconnect the negative cable to the battery.
24. Reset the clock.
25. Check the operation of the AM/FM CD tuner as described in the owner's manual supplied.
26. Reinstall all removed parts.
27. Put the Accessory User's Information Manual in the glove box for your customer.
28. Do the ECU idle learn procedure:
 - Make sure all electrical items are turned off.
 - Start the engine. Hold the engine speed at 3,000 rpm with no load (in Park or Neutral) until the radiator fan comes on.
 - Let the engine idle for about 5 minutes with the throttle fully closed and with all electrical items off.

NOTE: If the radiator fan comes on during this step, the time when it is operating must not be included in the 5 minutes.

NOTE: When the battery is disconnected, the driver's window AUTO function is disabled.

- Start the engine. Push down on the driver's window switch until the window is fully open.
- Pull up on the driver's window switch to close the window completely, then hold the switch for 2 seconds or more.
- Lower and raise the driver's window to check operation of the driver's window AUTO function.