



# INSTALLATION INSTRUCTIONS

Accessory

**COURTESY LIGHTS  
P/N 08E10-SNA-110**

Application

**2009 CIVIC  
HYBRID**

Publications No.

**All 40150**

Issue Date

**AUG 2008**

## PARTS LIST

Courtesy light (with blue tape)

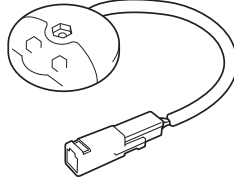

2 Courtesy lights (with white tape)

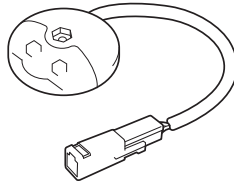

Courtesy light harness

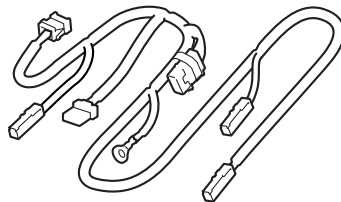

Bracket

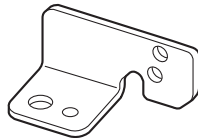

Wire tie with clip

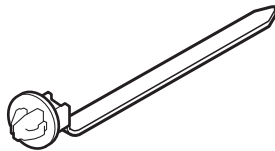

Switch trim

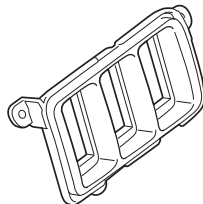

2 Switch lids



3 Screws



3 Flange nuts



Switch

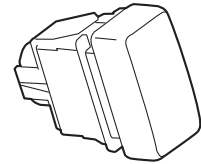

Template

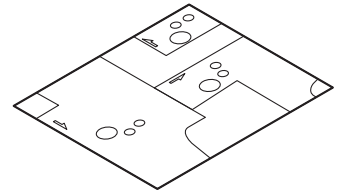

Fuse label

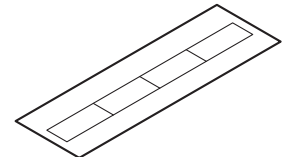

10 Wire ties

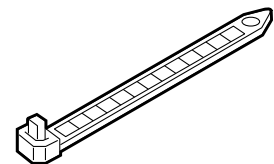

EPT sealer

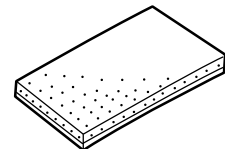

**Illustration of the Courtesy Lights Installed on the Vehicle**

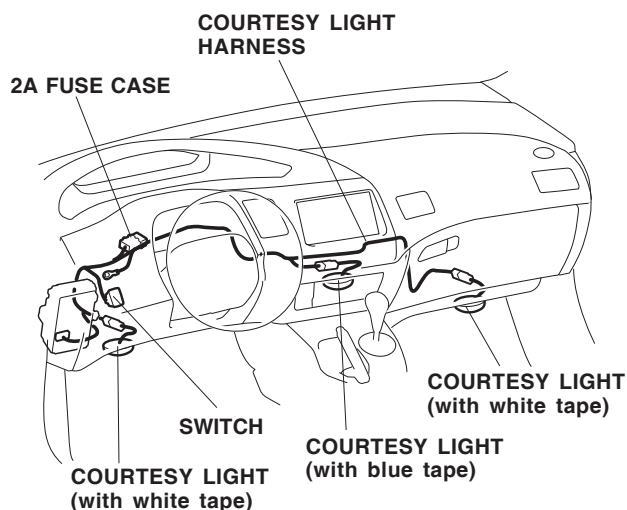

**TOOLS AND SUPPLIES REQUIRED**

- Phillips screwdriver
- Flat-tip screwdriver
- Ratchet
- 10 mm Socket
- Drill
- Drill bits (3 mm, 5 mm, and 10 mm)
- File
- Pushpin
- Utility knife
- Scissors
- Piece of steel wire
- Electrical tape
- Adhesive tape
- Eye protection (face shield, safety goggles, etc.)
- Scale
- Shop towel

**INSTALLATION**

**Customer Information:** The information in this installation instruction is intended for use only by skilled technicians who have the proper tools, equipment, and training to correctly and safely add equipment to your vehicle. These procedures should not be attempted by “do-it-yourselfers.”

1. Make sure you have the anti-theft code for the radio, then write down the radio station presets.
2. Disconnect the negative cable from the battery.

3. If equipped, remove the driver’s dashboard under cover (turn the knob counterclockwise, and release two clips and then the pin).

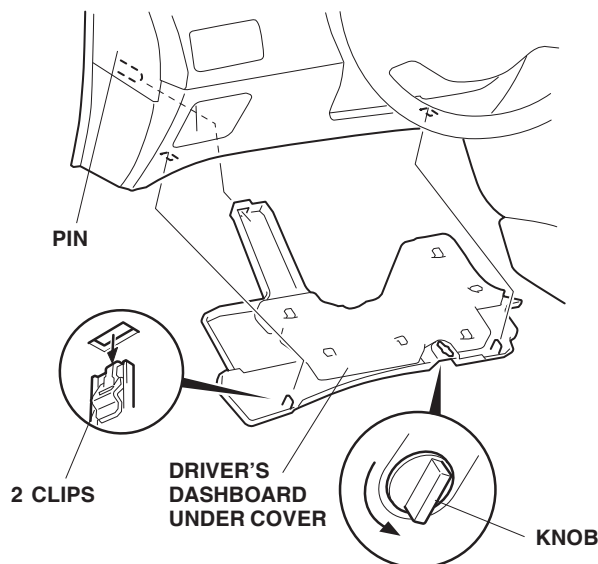

4. Remove the driver’s dashboard lower cover (eight clips).

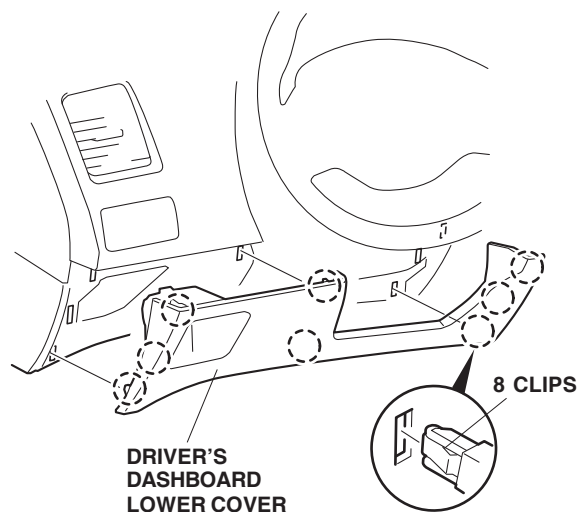

- Lower the tilt lever, and move the steering wheel to its lowest position. After moving the steering wheel, return the tilt lever to its original position.

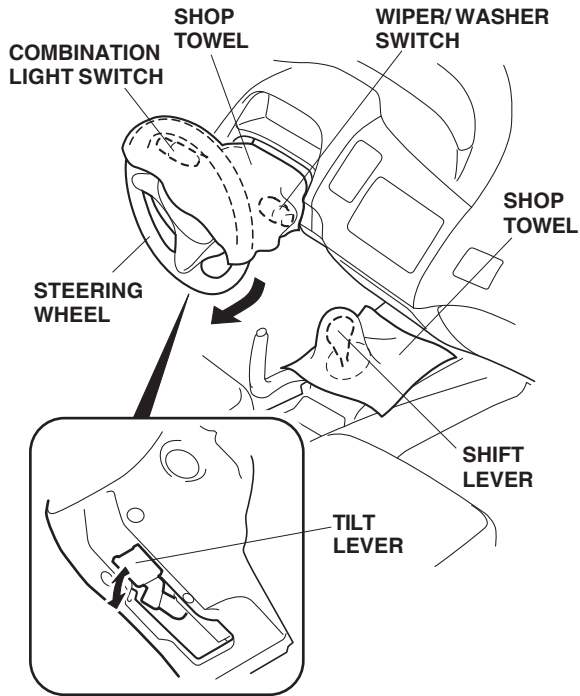

- Cover the combination light switch, wiper/washer switch, and shift lever with a shop towel to protect them from damage.
- Apply masking tape to the dashboard. Remove the instrument panel (one self-tapping screw and 11 clips), and unplug the vehicle connector.

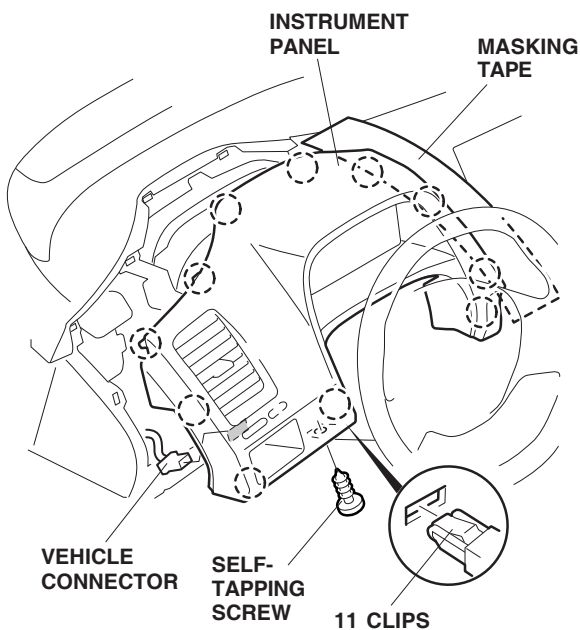

- Shift to S or 2, and remove the lid from the dashboard center lower cover (four retaining tabs).

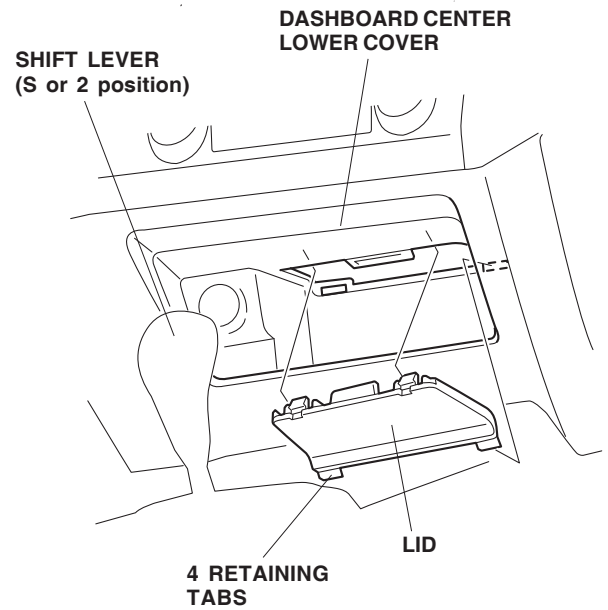

- Remove the passenger's dashboard under cover (four clips and two pins).

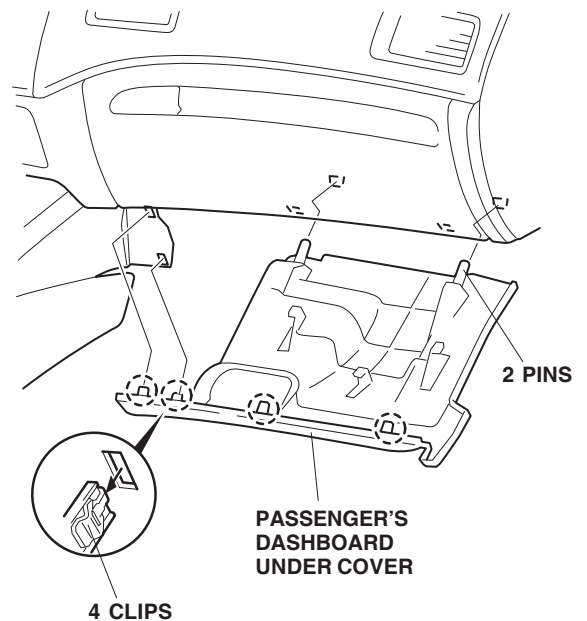

- Remove the two bolts. Open the glove box, push inward on the stoppers, and remove the glove box.

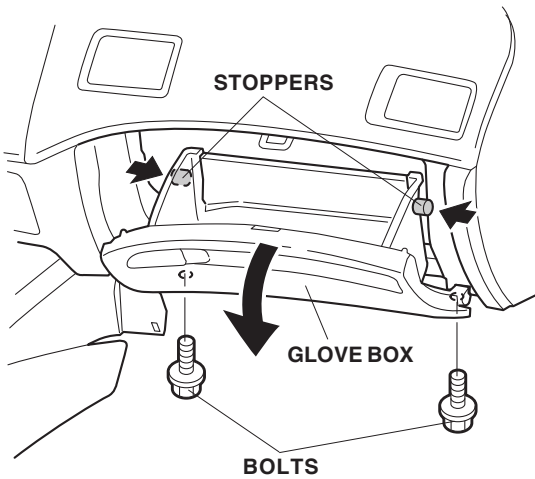

### Routing the Courtesy Light Harness

- Route the courtesy light harness 5-pin connector behind the fuse box, and pull it out through the opening of the air duct.

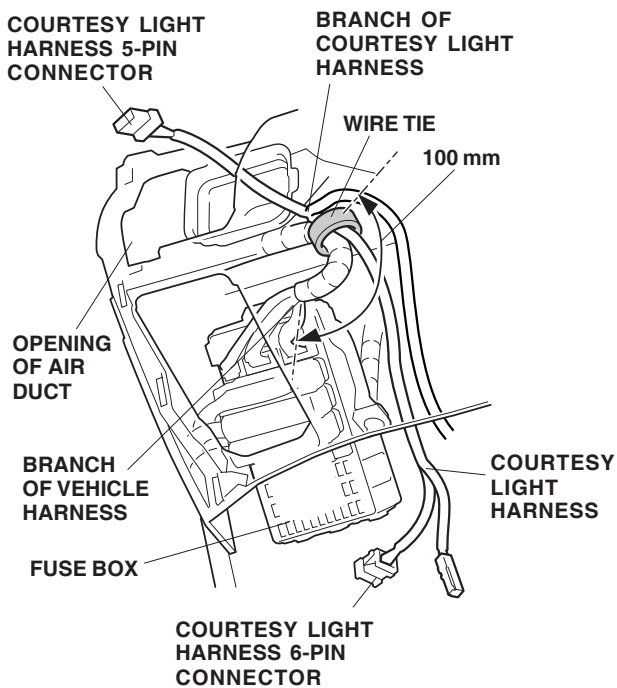

- Measure the vehicle harness from the point of branch as shown. Secure the courtesy light harness (6-pin connector side) to the vehicle harness with one wire tie.

- Plug the courtesy light harness 6-pin connector into the fuse box 6-pin connector.

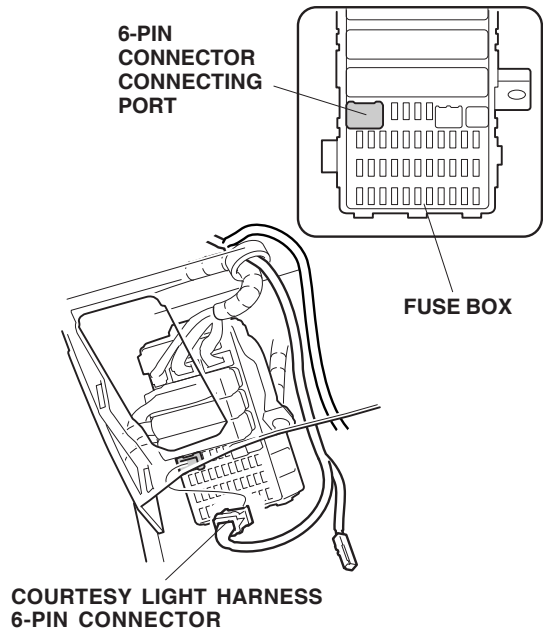

NOTE: If another accessory is already plugged into the 6-pin connector, remove the dummy connector from the other accessory harness, and plug the courtesy light harness into that connector.

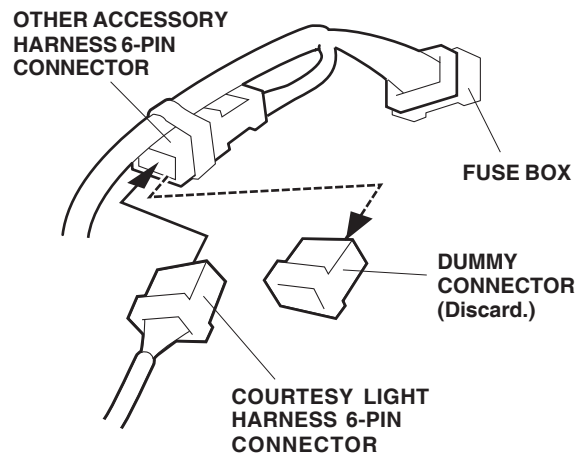

- Route the two courtesy light harness 2-pin connectors onto the right side of the vehicle along the vehicle harness.

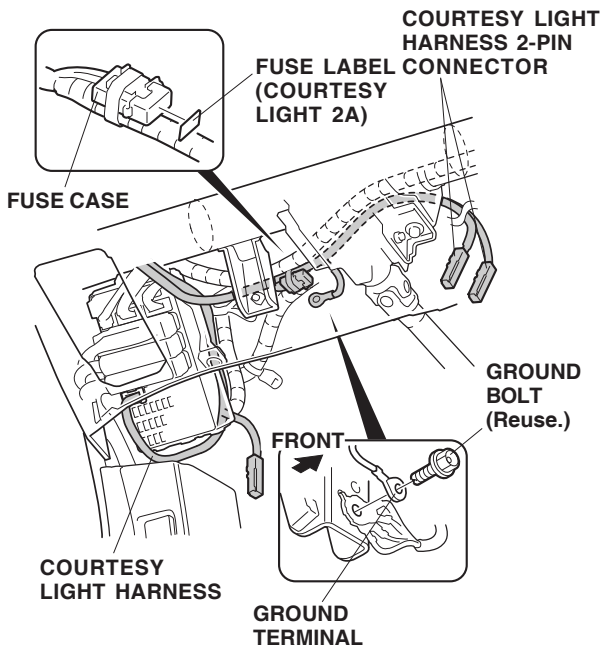

- Attach the 2A fuse label to the courtesy light harness fuse case.
- Remove the ground bolt from the vehicle. Secure the courtesy light harness ground terminal with the ground bolt you just removed.

- Route the wire through the opening for the lid of the dashboard center lower cover, and wind it onto the courtesy light harness 2-pin connector (long harness side).

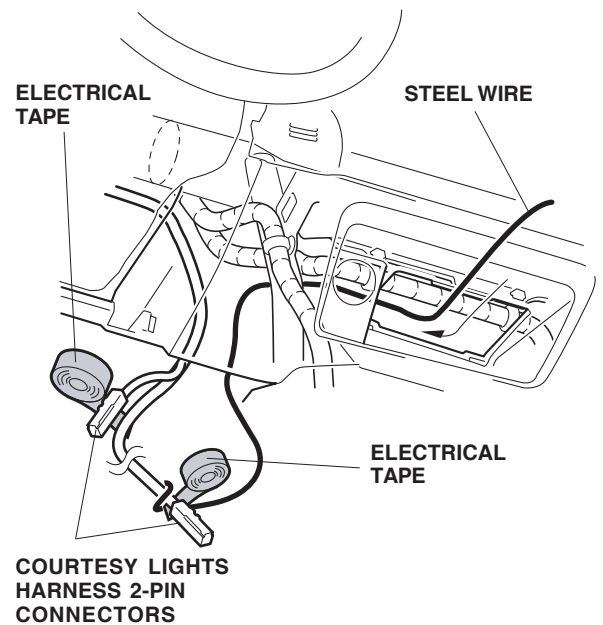

- Secure the other 2-pin connector to the courtesy light harness with electrical tape.
- Pull the courtesy light harness out of the lid opening of the dashboard center lower cover by pulling the wire.

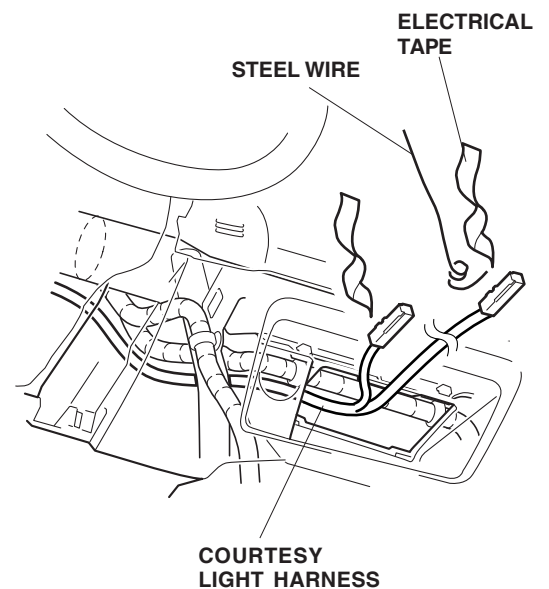

- Remove the wire and electrical tape from the courtesy light harness.

21. Route the courtesy light harness 2-pin connector to the passenger's side along the vehicle harness.

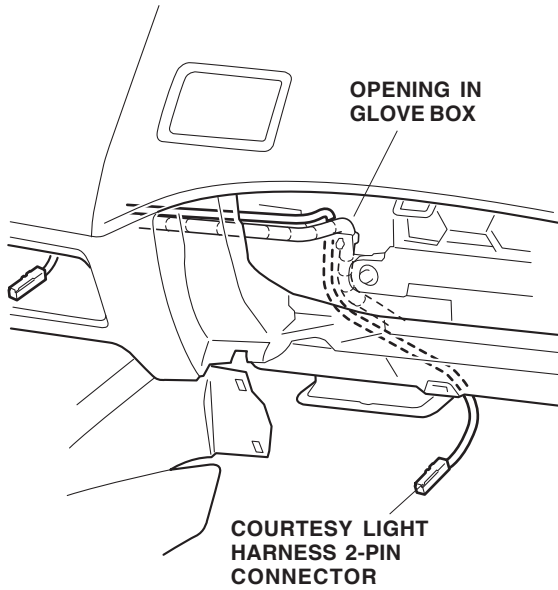

22. Secure the courtesy light harness to the vehicle harness with two wire ties.

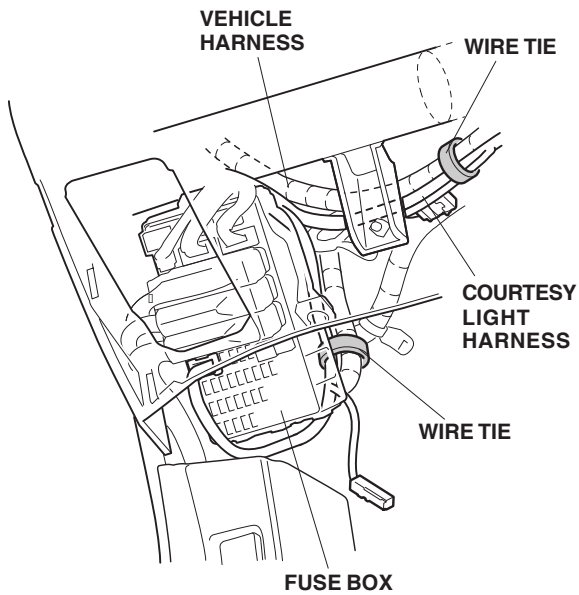

23. Secure the courtesy light harness to the vehicle harness with three wire ties.

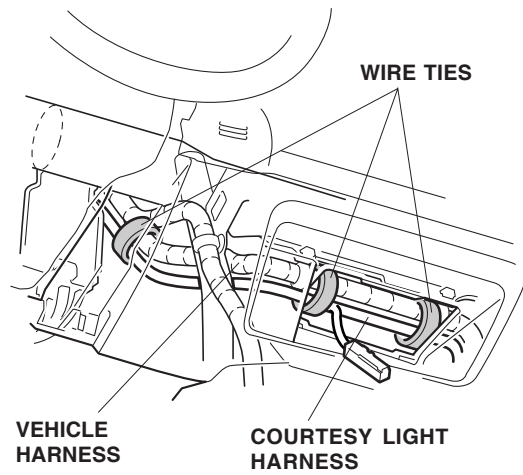

24. Secure the courtesy light harness to the vehicle harness using four wire ties.

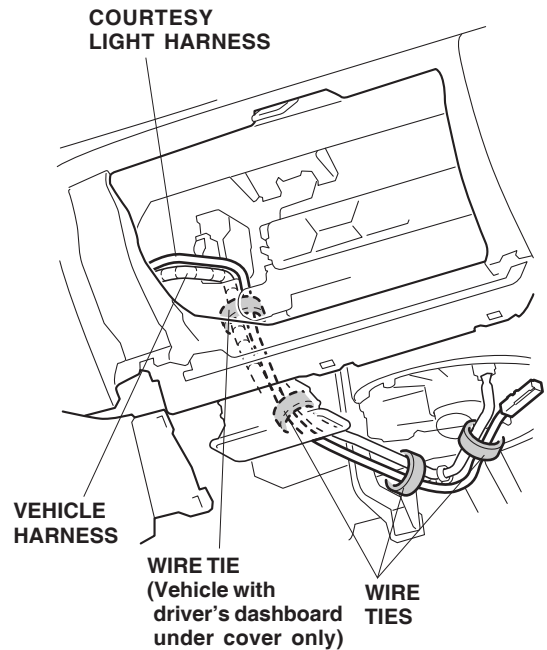

## Installing the Courtesy Lights

25. Using scissors, cut out the template.

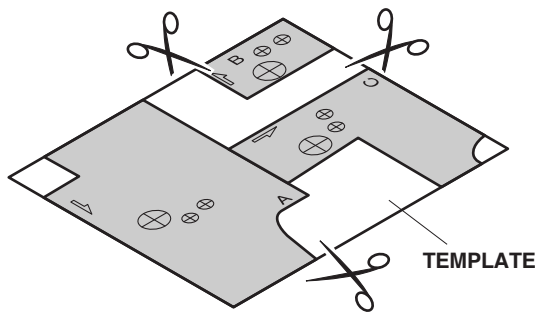

*If the vehicle is equipped without a driver's dashboard under cover, go to step 34; otherwise, continue with step 26.*

26. Pull up the insulator on the driver's dashboard under cover, and cut into it as shown.

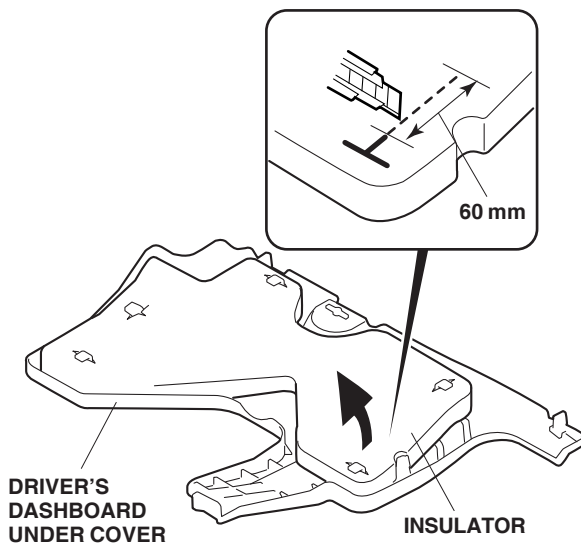

27. Secure the template (A) to the driver's dashboard under cover with tape by aligning it with the square hole at the end of the curve as shown.

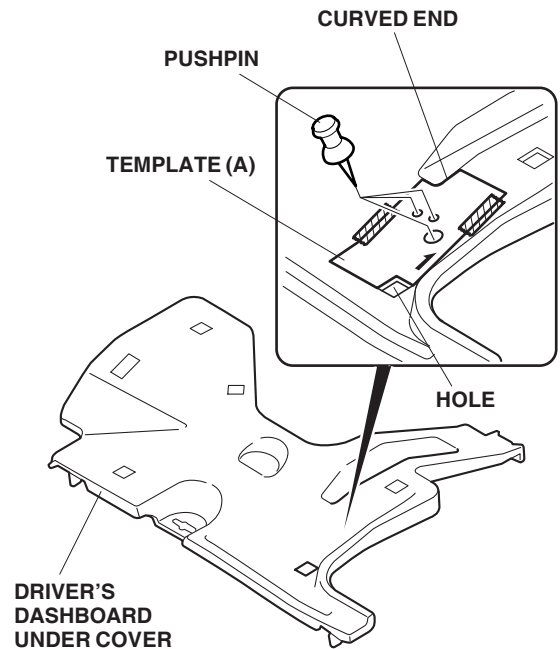

28. Using a pushpin, pierce the template at the three marked points. Remove the template.

29. While wearing eye protection, drill one 10 mm hole and two 5 mm holes at the pierced points on the driver's dashboard under cover. First drill with a 3 mm bit, then finish with a 5 mm bit/10 mm bit as shown. Using a file, remove any burrs from the holes.

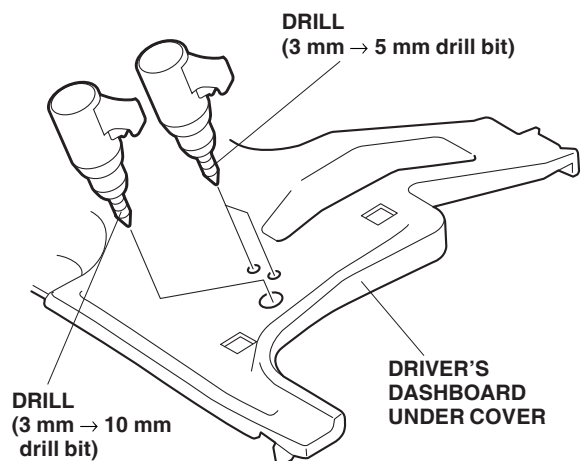

30. Cut the rib of the driver's dashboard under cover as shown. Using a file, remove any burrs from the edge.

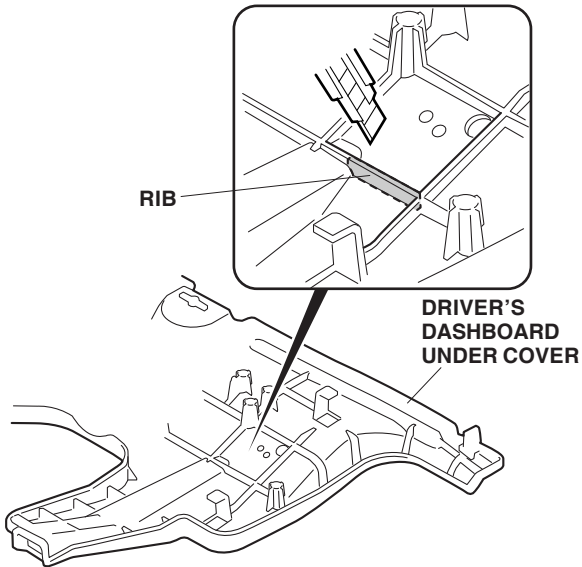

31. Route one courtesy light (with white tape) connector through the 10 mm hole. Install the courtesy light and bracket on the driver's dashboard under cover with the screw and flange nut.

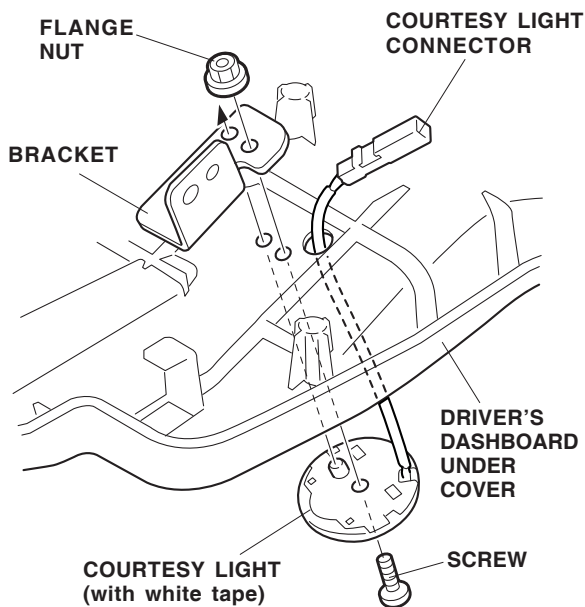

32. Bundle the courtesy light harness and secure the connector to the bracket using a wire tie with clip.

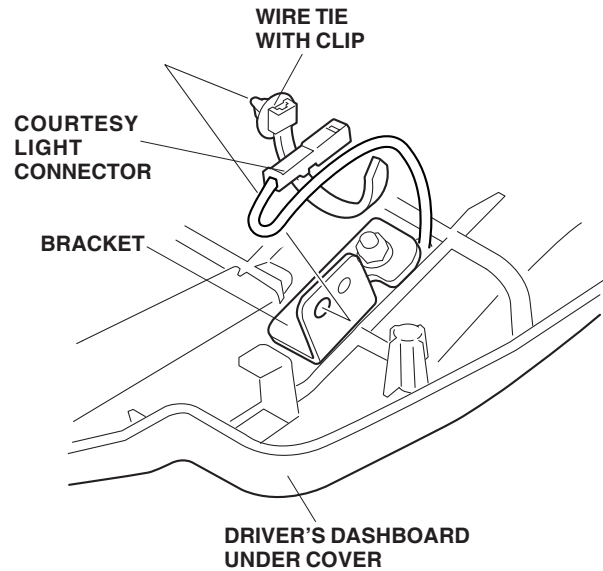

33. Reinstall the insulator to the driver's dashboard under cover, and pass the courtesy light connector through the slit.

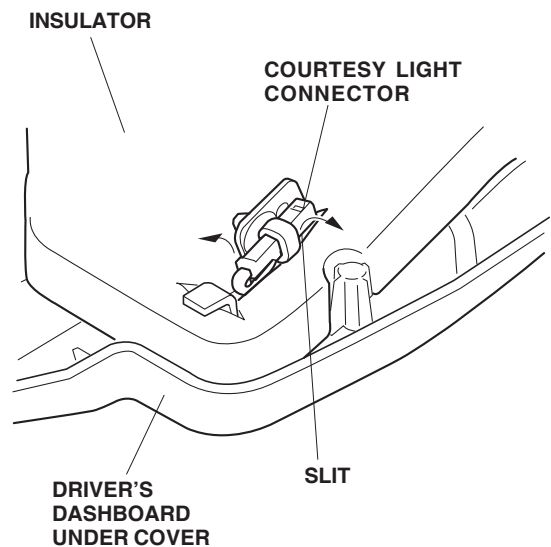

34. Position the template (B) on the lid of the dashboard center lower cover.

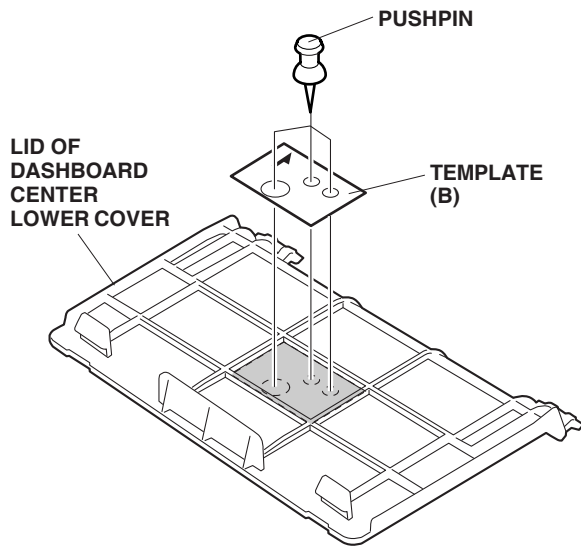

35. Using a pushpin, pierce the template at the three marked points. Remove the template.
36. While wearing eye protection, drill one 10 mm hole and two 5 mm holes at the pierced points on the lid. First drill with a 3 mm bit, then finish with a 5 mm bit, and 10 mm bit as shown. Using a file, remove any burrs from the holes.

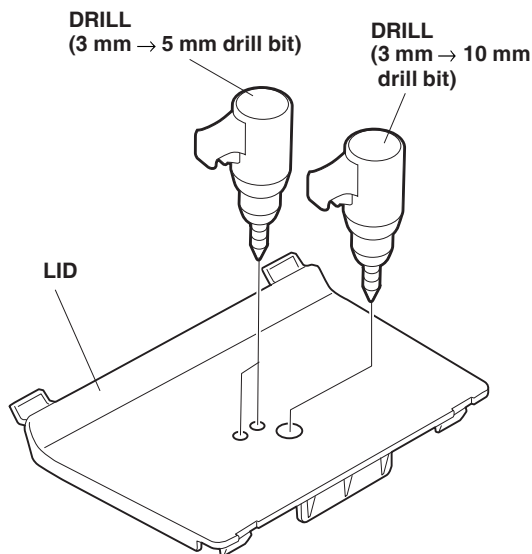

37. Route the courtesy light (with blue tape) connector through the 10 mm hole. Install the courtesy light on the lid with the screw and flange nut.

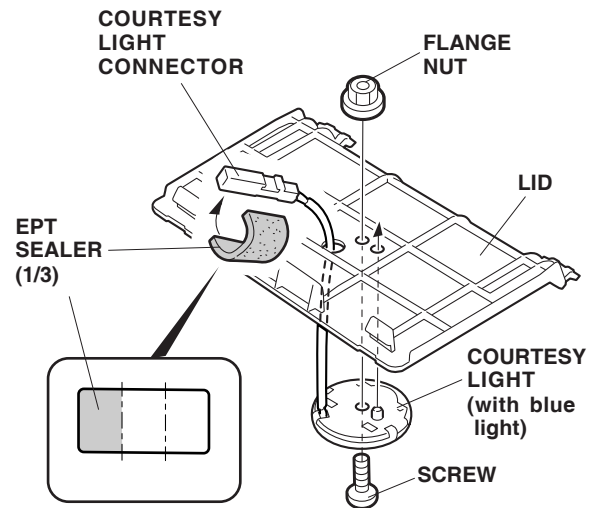

38. Using scissors, cut one EPT sealer into three equal pieces and use one of the pieces to wrap around the courtesy light connector.
39. Secure the template (C) to the passenger's dashboard under cover with tape by aligning it with the square hole and the end of the curve as shown. Do not use the marks on the inside of the passenger's dashboard under cover.

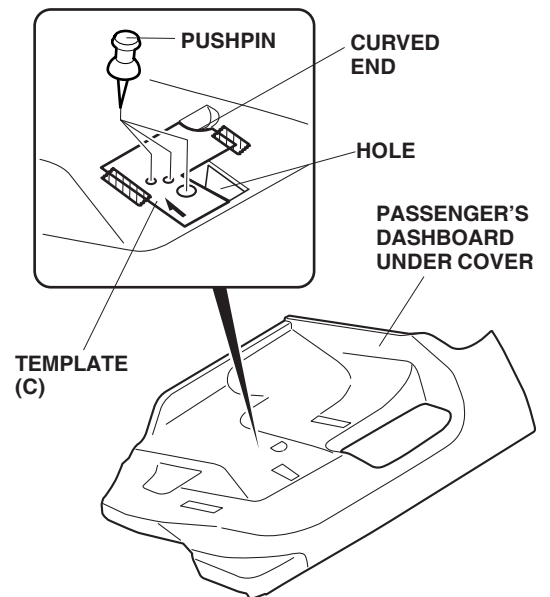

40. Using a pushpin, pierce the template at the three marked points. Remove the template.

41. While wearing eye protection, drill one 10 mm hole and two 5 mm holes at the pierced points on the passenger's dashboard under cover. First drill with a 3 mm bit, then finish with a 5 mm bit, and 10 mm bit as shown. Using a file, remove any burrs from the holes. Do not use the marks on the inside of the passenger's dashboard under cover.

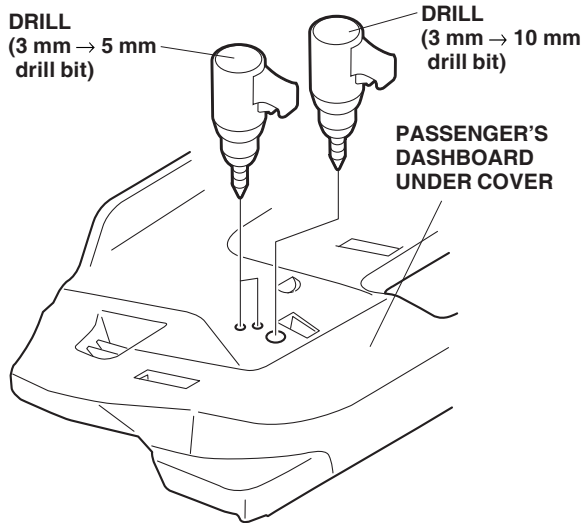

42. Route the other courtesy light (with white tape) connector through the 10 mm hole. Install the courtesy light on the passenger's dashboard under cover with the screw and flange nut.

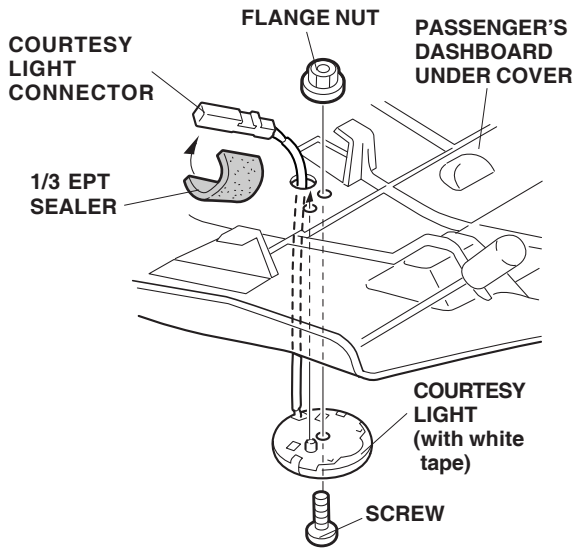

43. Wrap another piece of the EPT sealer that you cut into three equal pieces around the courtesy light connector.

44. Remove the pocket from the instrument panel (three self-tapping screws).

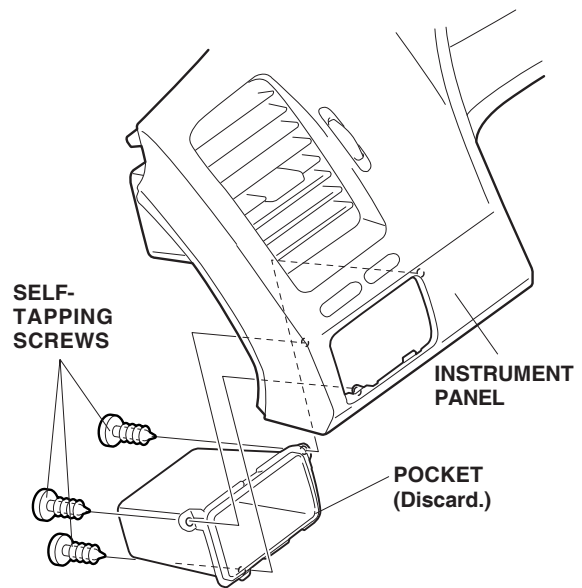

45. Install the switch trim to the instrument panel with the three self-tapping screws.

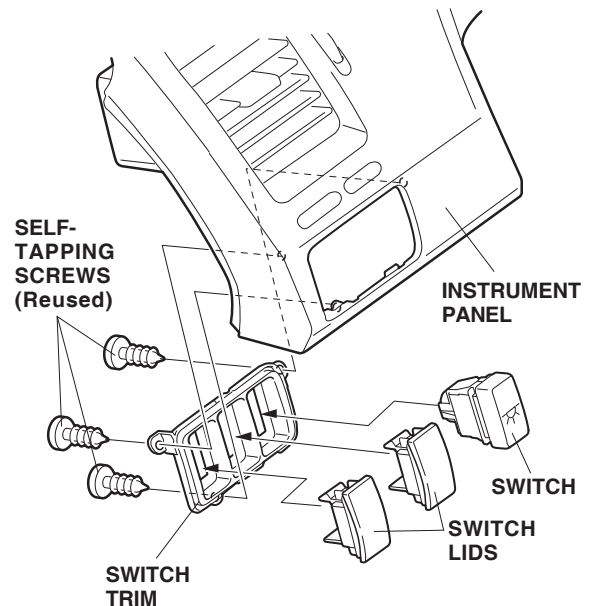

46. Install the switch and two switch lids to the switch trim.

47. Plug the courtesy light harness 5-pin connector to the switch, and reinstall the instrument panel.

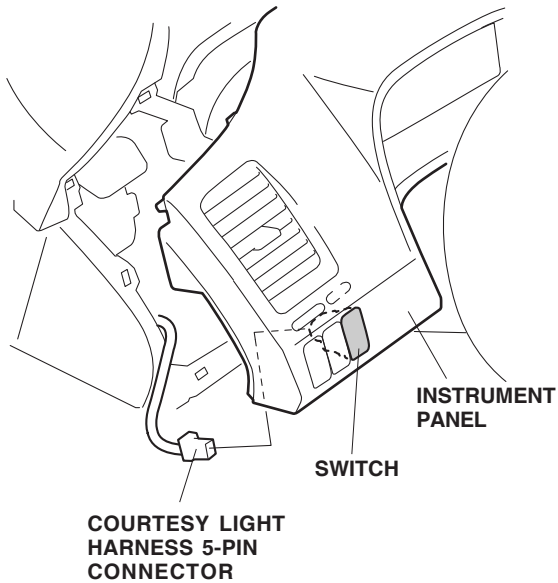

48. Reinstall the driver's dashboard lower cover and glove box.  
 49. Plug the courtesy light harness 5-pin connector to the switch, and reinstall the instrument panel.

50. Reinstall the driver's dashboard lower cover and glove box.

51. If equipped with the driver's dashboard under cover, plug the courtesy light connector on the driver's dashboard under cover, and reinstall the under cover.

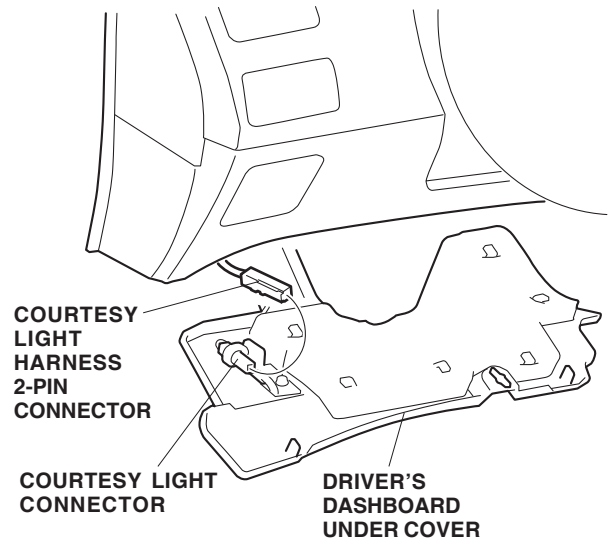

52. Plug the courtesy light harness 2-pin connector to the courtesy light connector on the lid of the dashboard center lower cover, and reinstall the lid.

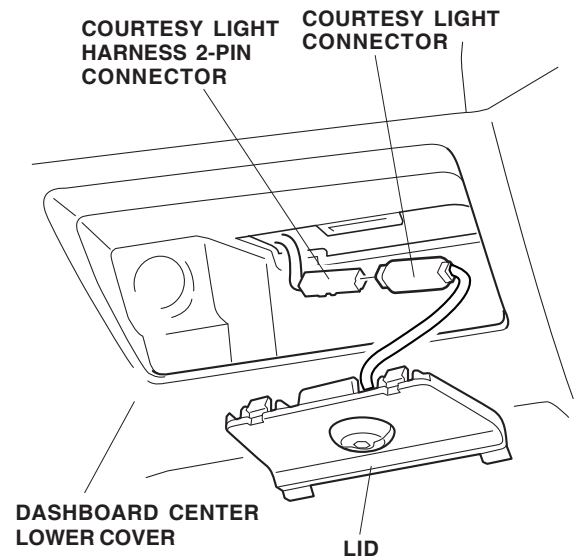



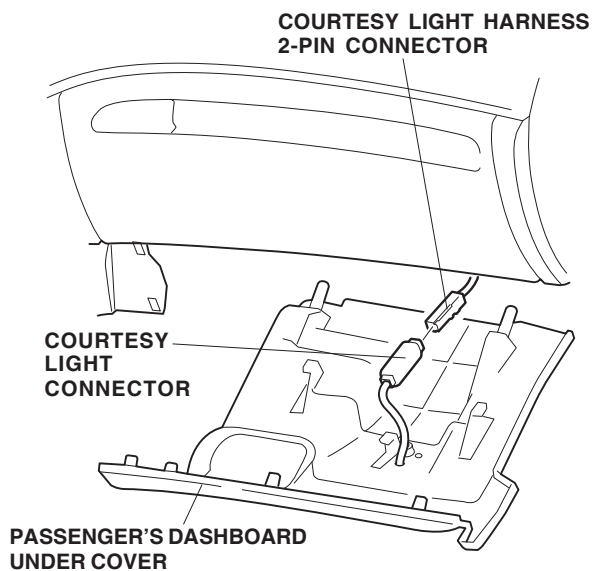



53. Plug the courtesy light harness 2-pin connector to the courtesy light connector on the passenger's dashboard under cover, and reinstall the under cover.

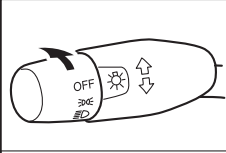

54. Check that all wire harnesses are routed properly and all connectors are plugged in.
55. Reinstall all removed parts. Check that all clips and other fasteners are installed securely.
56. Reconnect the negative cable to the battery.
57. Enter the customer's audio unit anti-theft code, and reset the radio station presets.
58. Reset the clock.
59. If the IMA battery level gauge (BAT) displays zero segments, start the engine, and hold it between 3,500 and 4,000 rpm (in Park or Neutral) until the gauge displays at least three segments.
60. Initialize the auto up/down feature of the front windows.

## HOW TO OPERATE

- Turn the headlight switch to the “” and “” position (headlights on low beam).
- Press the courtesy light switch.

					
		<b>HEADLIGHT SWITCH</b>			
		<b>OFF</b>			
	<b>COURTESY LIGHT SWITCH</b>	<b>ON</b>	-	<b>ON</b>	<b>ON</b>
	<b>OFF</b>	-	-	-	