



# INSTALLATION INSTRUCTIONS

Accessory	Application	Publications No.
<b>AUTOMATIC DAY/NIGHT MIRROR WITH COMPASS</b>	<b>2009 CIVIC HYBRID</b>	<b>All 40146</b>
		Issue Date
		<b>AUG 2008</b>

Accessory	Application	Publications No.
<b>AUTOMATIC DAY/NIGHT MIRROR WITH COMPASS</b>	<b>2009 CIVIC HYBRID</b>	<b>All 40146</b>
		Issue Date
		<b>AUG 2008</b>

Accessory	Application	Publications No.
<b>AUTOMATIC DAY/NIGHT MIRROR WITH COMPASS</b>	<b>2009 CIVIC HYBRID</b>	<b>All 40146</b>
		Issue Date
		<b>AUG 2008</b>

## PARTS LIST

### Automatic Day/Night Mirror With Compass P/N 08V03-SDA-100B

Day/night mirror

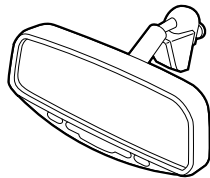

Spring



User's information manual

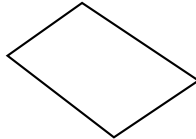

### Automatic Day/Night Mirror Attachment Kit P/N 08V03-SNA-100

Upper and lower covers

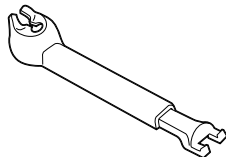

Day/night mirror harness

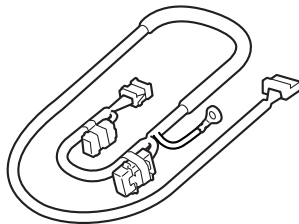

8 Wire ties

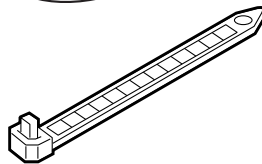

5 EPT sealers

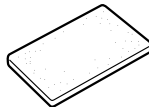

Clip



## TOOLS AND SUPPLIES REQUIRED

Phillips screwdriver

Flat-tip screwdriver

T25 TORX bit

Ratchet

10 mm Socket

Isopropyl alcohol

Shop towel

Piece of steel wire

Tape

Long nose pliers

Small rubber mallet

Tape measure

### Illustration of the Day/Night Mirror Installed on the Vehicle

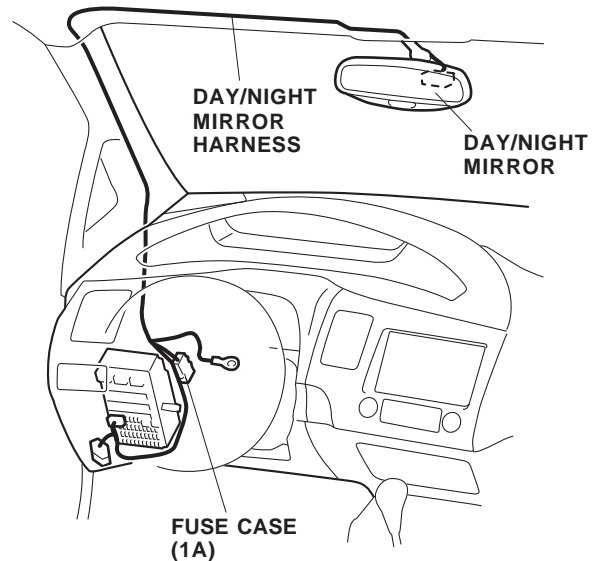

## INSTALLATION

**Customer Information:** The information in this installation instruction is intended for use only by skilled technicians who have the proper tools, equipment, and training to correctly and safely add equipment to your vehicle. These procedures should not be attempted by "do-it-yourselfers."

1. Make sure you have the anti-theft code for the audio unit, then write down the frequencies for the preset buttons.
2. Disconnect the negative cable from the battery.
3. If equipped with a map light console, use a small flat-tip screwdriver to remove the left and right lens from the map light console (four retaining tabs for each lens). Remove the map light console:
  - Remove the two bolts, and unplug the vehicle 3-pin connector. Then remove the switch (four retaining tabs and unplug the two vehicle connectors).

### With Moonroof and Navigation System

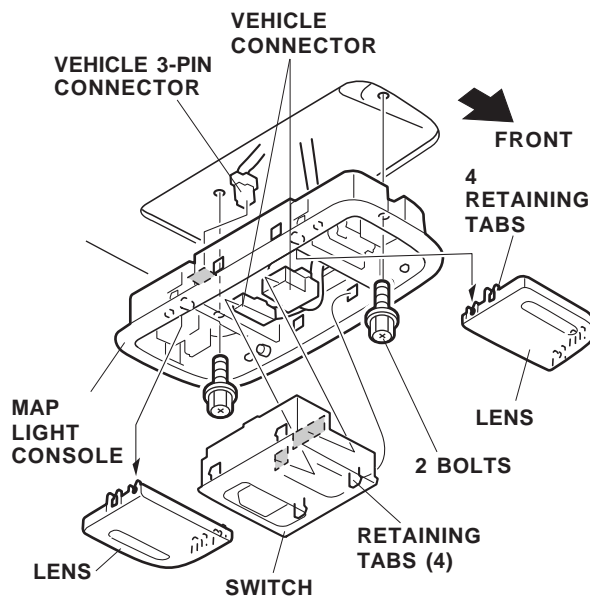

### Other Vehicles

- Remove the two bolts, and unplug the vehicle connector(s).

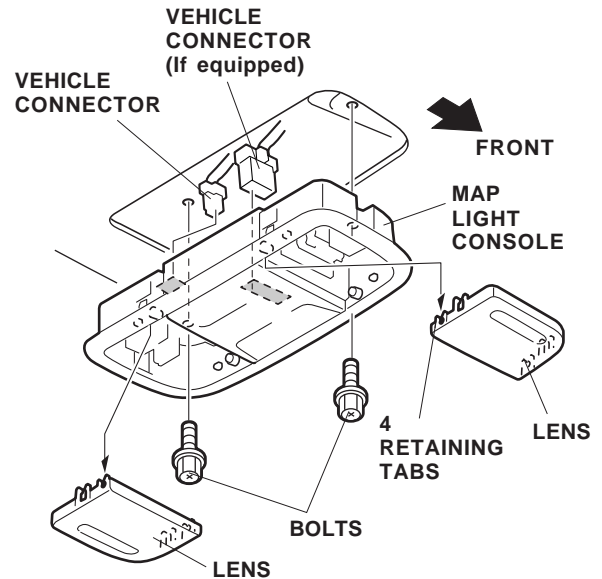

4. Remove the sunvisor holders. Using a flat-tip screwdriver, push the hook, turn the holder 90°, then pull it out.

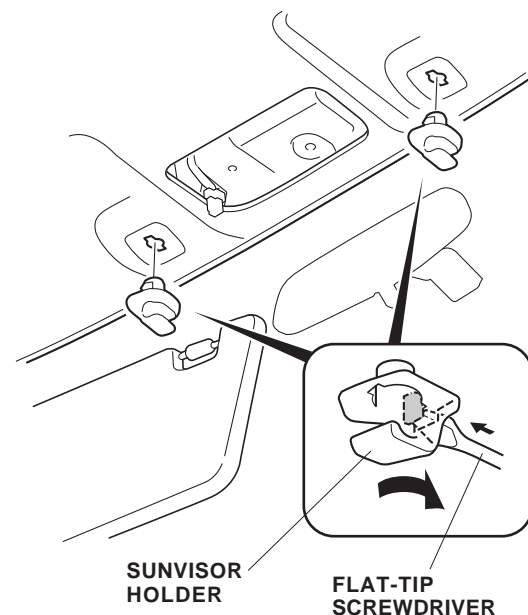

- Remove the cap from the left sunvisor (four retaining tabs).

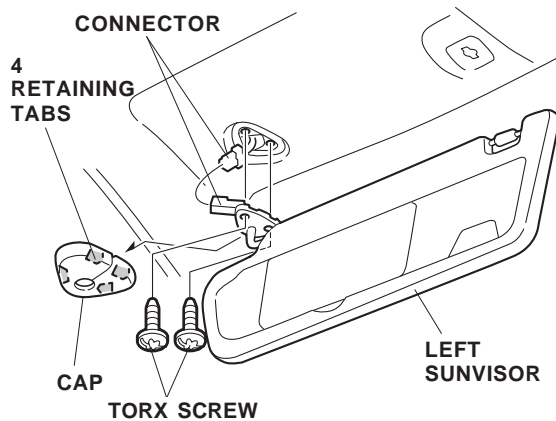

- Remove the left sunvisor (two T25 TORX screws, and unplug the vehicle connectors).
- Repeat steps 5 and 6 to remove the right sunvisor.
- Remove the rearview mirror from the holder by rotating the stay 90° clockwise.

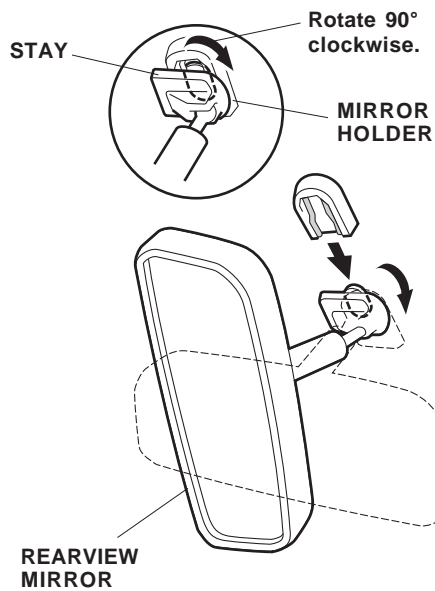

- Pull away the weatherstrip from the left front pillar trim.

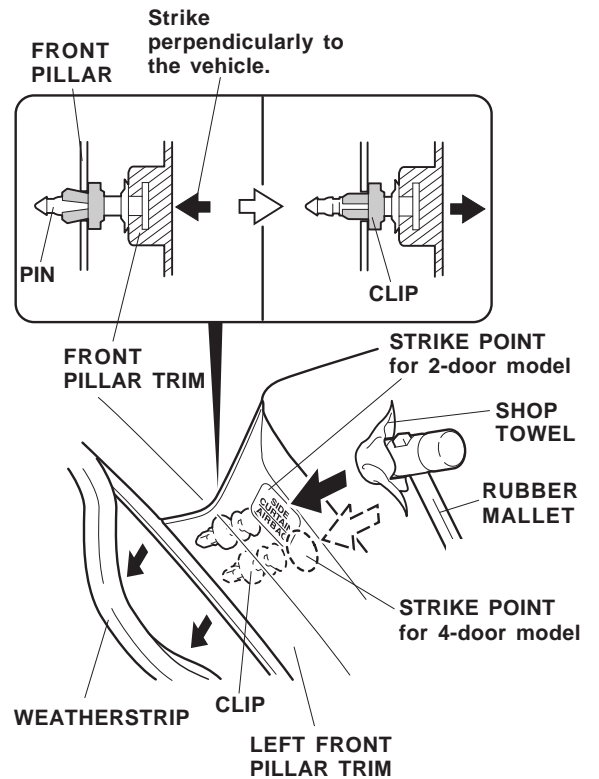

- Use a small rubber mallet and a shop towel to release the clip on the left front pillar trim. Tap the trim just under the "SIDE CURTAIN AIRBAG" marking.
- Pull away the weatherstrip from the left front pillar trim. Remove the left front pillar trim (two clips).

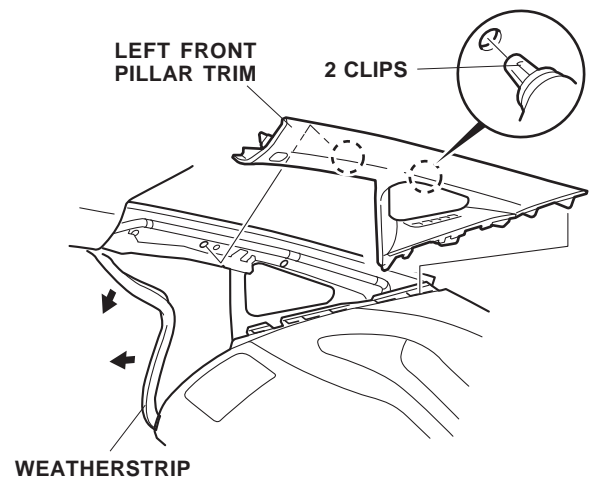

12. Remove the clip from the left front pillar trim.

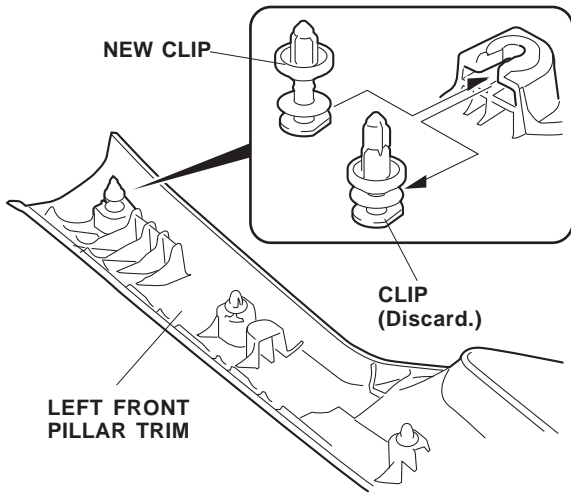

13. Install a new clip on the left front pillar trim.

14. Lower the left front grab rail and remove the two caps using a flat-tip screwdriver.

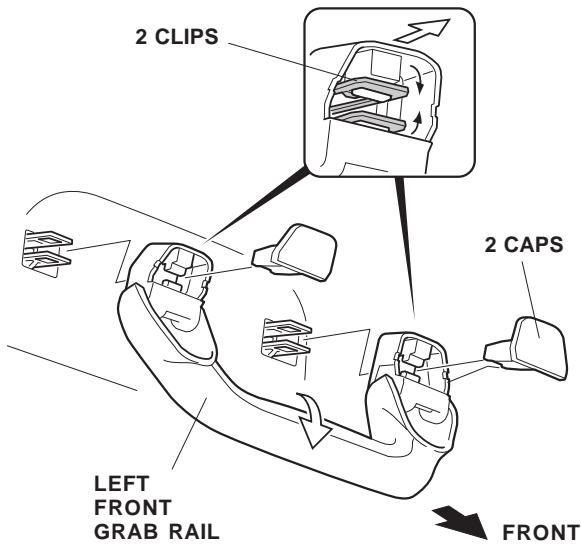

15. Using a flat-tip screwdriver, remove the grab rail from its two clips.

16. If equipped, remove the driver's dashboard under cover (turn the knob 90° counterclockwise, and release two clips and pin).

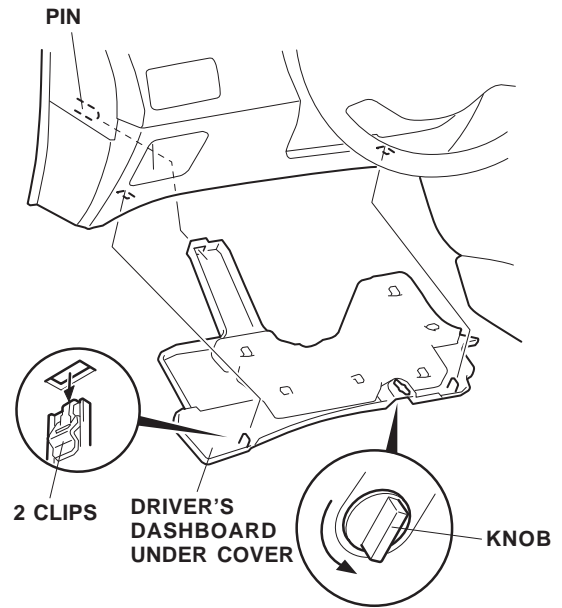

17. Remove the driver's dashboard lower cover (eight clips).

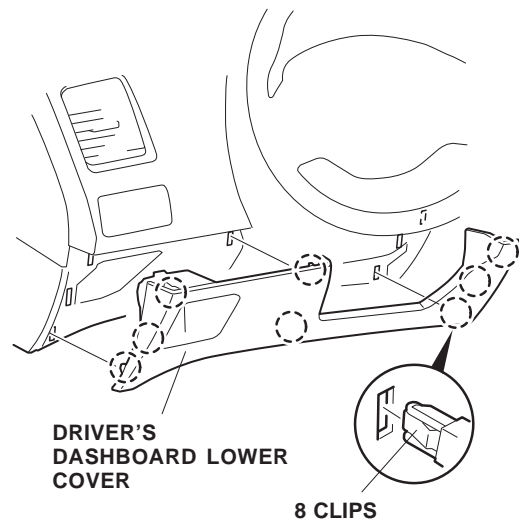

- Replace the spring. Slide the day/night mirror stay onto the mirror holder, then turn the mirror counterclockwise as shown.

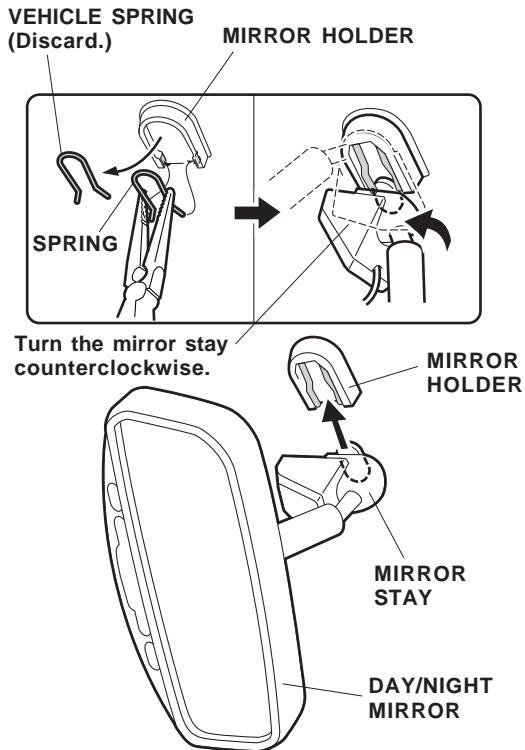

- Wrap one EPT sealer around the day/night mirror harness at the location shown.

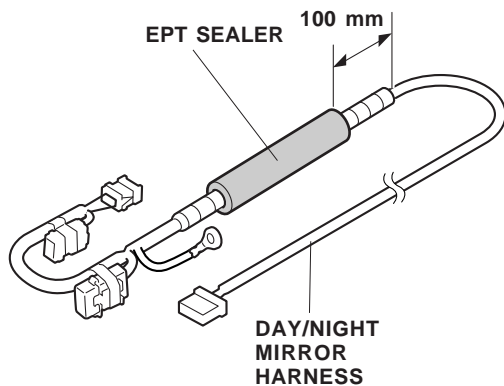

- Tape a piece of steel wire to the 7-pin connector end of the day/night mirror harness. Pull the 7-pin connector up and out through the clearance between the left front pillar and the instrument panel.

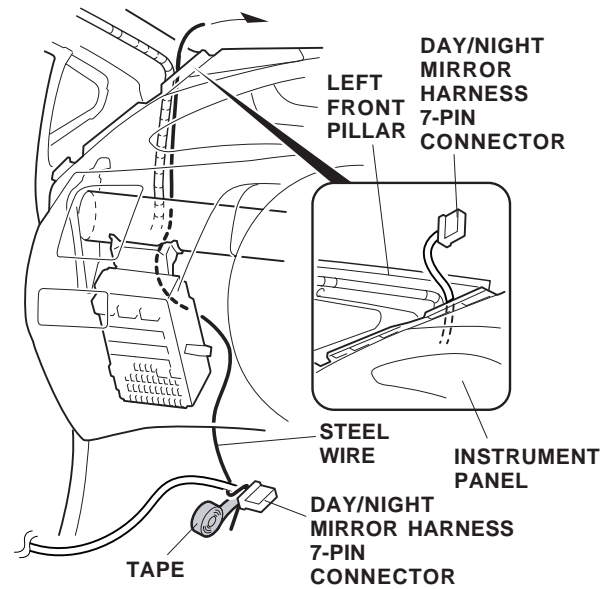

- Remove the tape and the steel wire from the day/night mirror harness.
- Continue routing the day/night mirror harness 7-pin connector up along the vehicle harness, and out from behind the roof liner near the mirror.

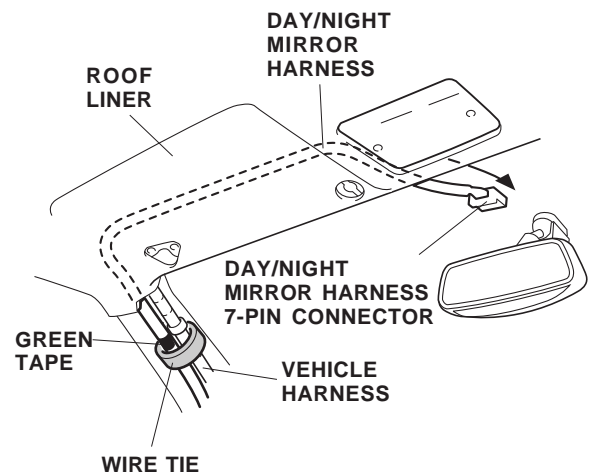

- Secure the day/night mirror harness to the vehicle harness with one wire tie at the green tape.

24. Plug the day/night mirror harness 7-pin connector into the rear of the mirror.

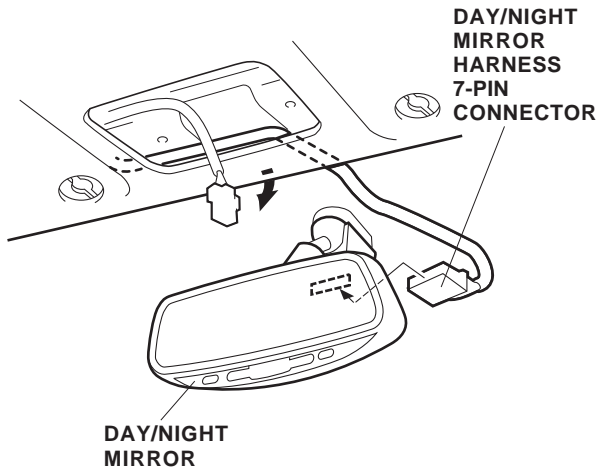

25. Measure the day/night mirror harness in the area shown. Route the day/night mirror harness through the grooves in the upper and lower covers. Attach the lower cover to the mirror stay.

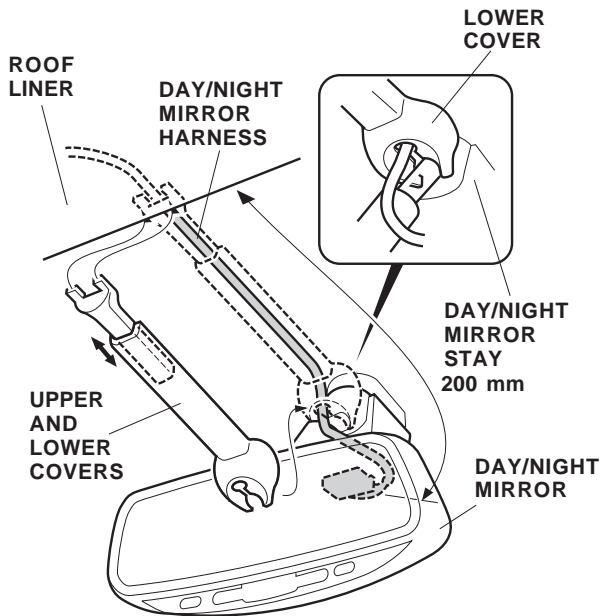

26. Slide the upper cover up under the roof liner.

27. Using isopropyl alcohol on a shop towel, clean the areas where the EPT sealer will attach. Under the roof liner, secure the day/night mirror harness to the roof panel with the four EPT sealers in the areas shown.

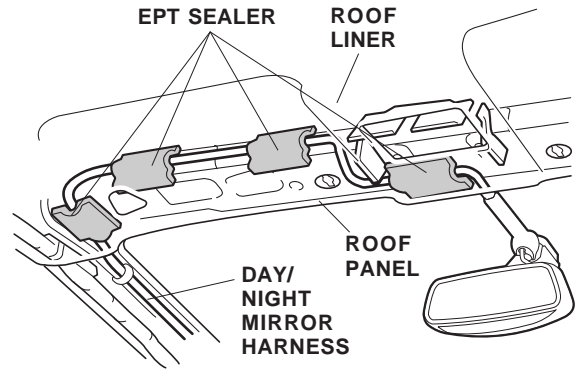

28. Secure the day/night mirror harness to the vehicle harness with three wire ties in the areas shown.

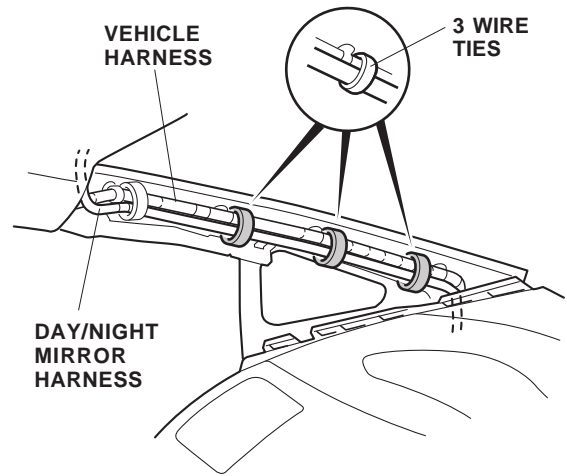

29. Plug the day/night mirror harness 6-pin connector into the 6-pin connector at the fuse box.

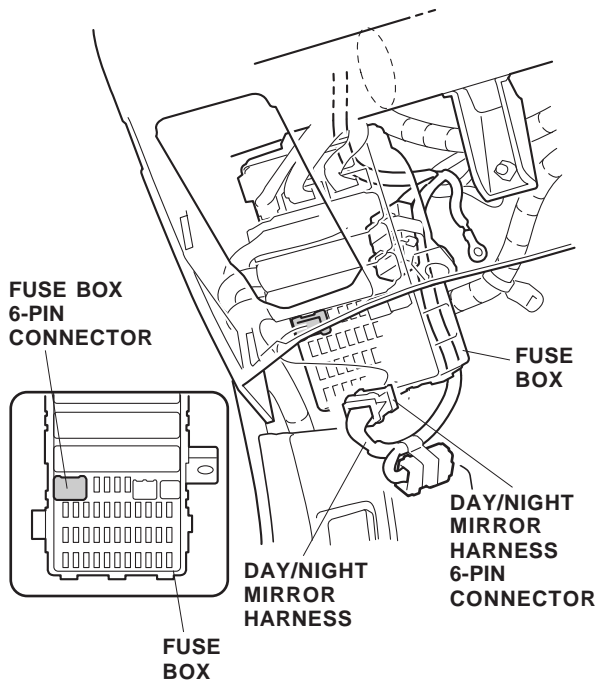

NOTE: If another accessory is already plugged into the 6-pin connector, remove the dummy connector from the 6-pin connector taped to the day/night mirror harness. Disconnect the 6-pin connector of the other accessory harness from the fuse box and connect it to this 6-pin connector.

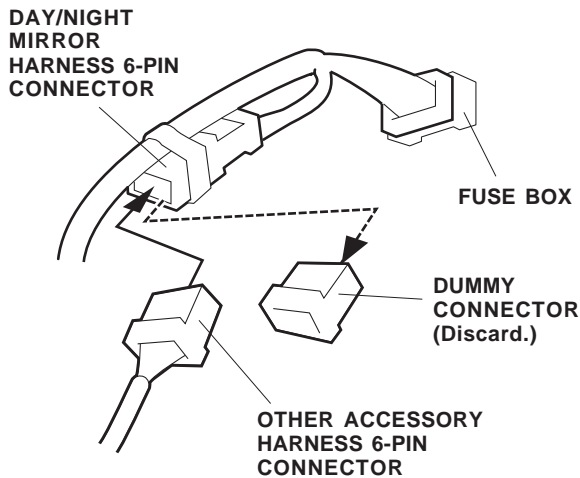

30. Remove the ground bolt from the vehicle bracket. Secure the day/night mirror harness ground terminal with the ground bolt you just removed.

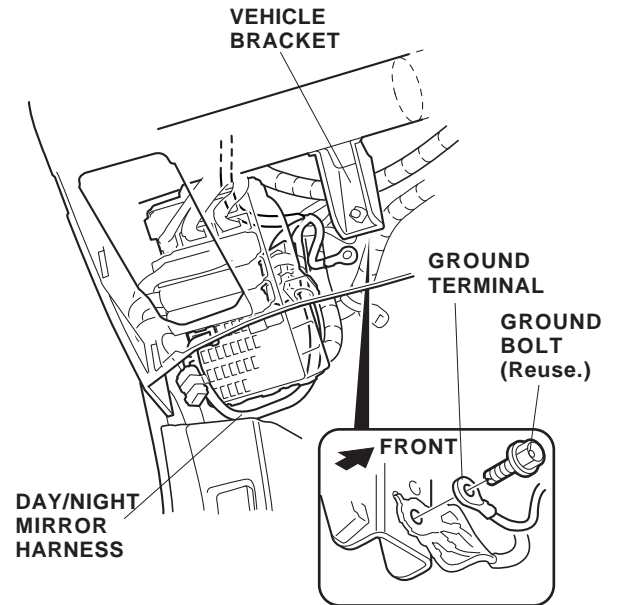

31. Secure the day/night mirror harness to the vehicle harness with four wire ties in the areas shown.

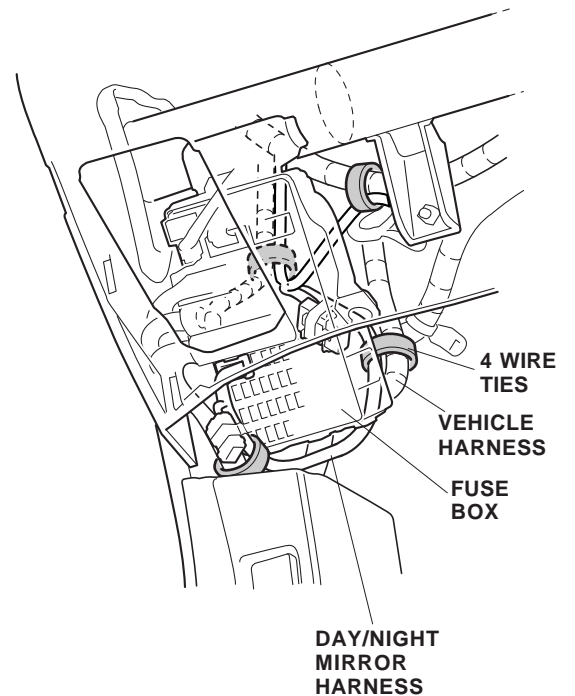

32. Check that all wire harnesses are routed properly and all connectors are plugged in.
33. Reinstall the grab rail; remove the two clips from the vehicle. After installing the clips and caps on the grab rail, reinstall the grab rail on the vehicle.

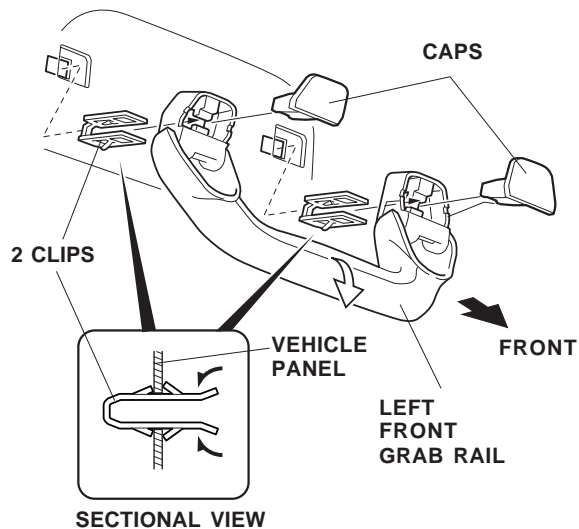

39. Check the operation of the automatic day/night mirror according to the User's information Manual supplied.
40. Initialize the auto up/down feature of the front windows.

34. Reinstall all removed parts. Check that all clips and other fasteners are installed securely. Take care not to pinch the airbag with a clip during reinstallation of the front pillar trim. Do not push the front pillar trim excessively.
35. Reconnect the negative cable to the battery.
36. Enter the customer's audio unit anti-theft code, and reset the radio station presets.
37. Reset the clock.
38. If the IMA battery level gauge (BAT) displays zero segments, start the engine, and hold it between 3,500 and 4,000 rpm (in Park or Neutral) until the gauge displays at least three segments.