



INSTALLATION INSTRUCTIONS

Accessory
DOOR VISORS
P/N 08R04-SWA-100

Application
2009 CR-V

Publications No.
All 40440
Issue Date
AUG 2008

NOTE: Visors may not be legal in all states. Please check the laws of your state

PARTS LIST

Door visor (Front left)

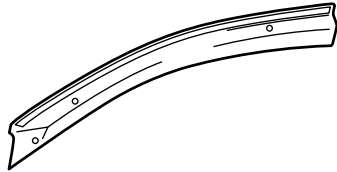

Door visor (Front right)



Door visor (Rear left)



Door visor (Rear right)



2 Brackets A



8 Brackets D



2 Brackets E

12 Clips

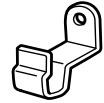

Primer

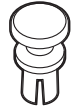

EPT sealer

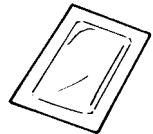

TOOLS AND SUPPLIES REQUIRED

Shop towel

Ruler

Felt-tip pen

Masking tape

Isopropyl alcohol

Scissors

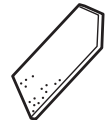
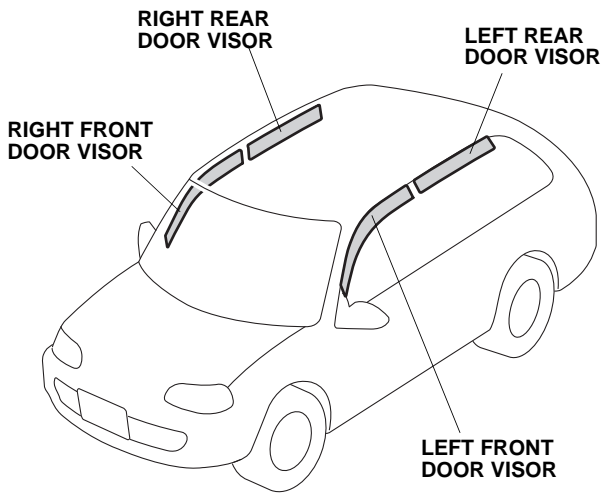

Illustration of the Door Visors on the Vehicle



INSTALLATION

NOTE:

- These instructions show the left door visors being installed. The same procedure applies to installing the right door visors.
- Be careful not to damage the paint finish or glass run channels when installing the door visors.
- Handle the door visors with care. They are not designed to absorb shock or impact.
- This door visor kit should be installed only if the ambient air temperature is 60° F (15°C) or above.
- To allow the adhesive to cure, do not wash the vehicle for 24 hours.

Installing the Rear Door Visors

1. Fully open the left rear door window.
2. Install two brackets D and one bracket E on the door sash trim in the positions shown.
 - Check the shape of each bracket and install them in the correct positions.
 - Check that the door run channel is installed properly.

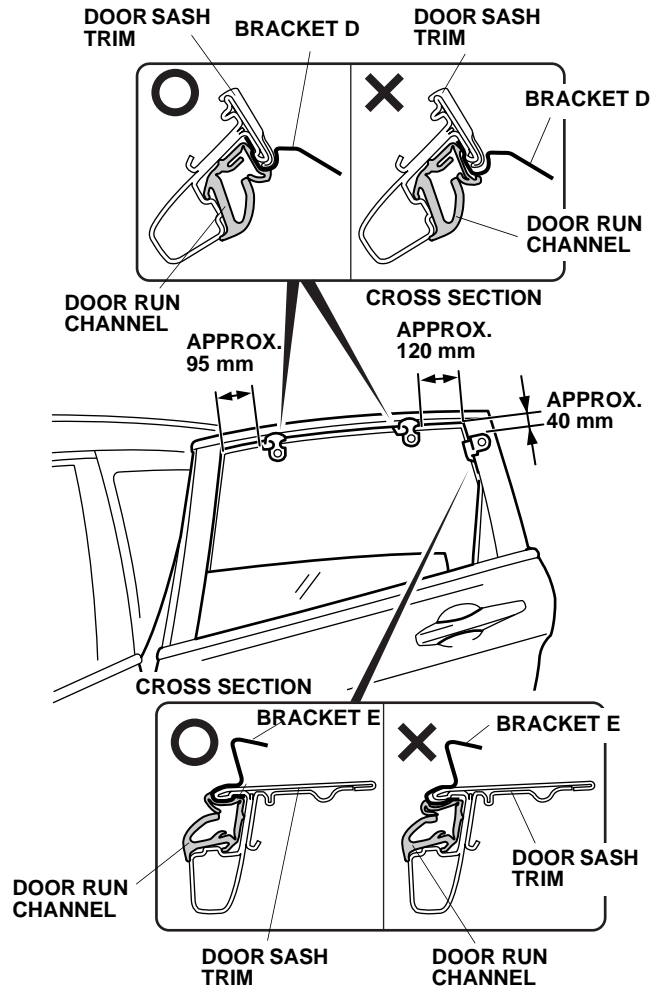

- Position the left rear door visor on the door sash trim. Adjust the positions of the two brackets D and bracket E, and temporarily install the door visor with the three clips.

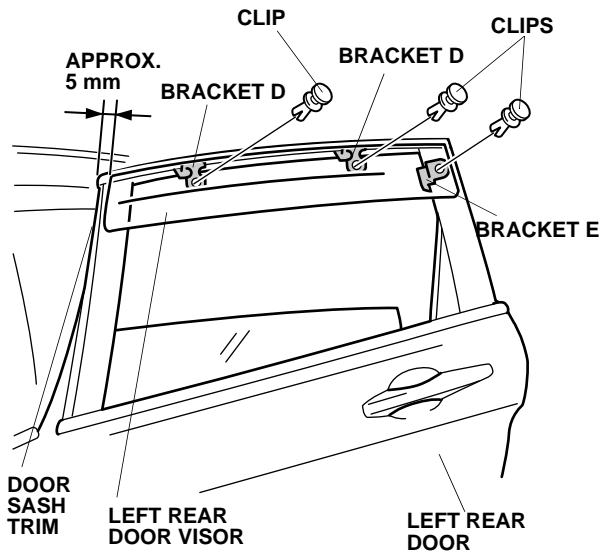

- Attach masking tape to the left rear door visor at both ends of the door visor, then remove the left rear door visor (three clips).

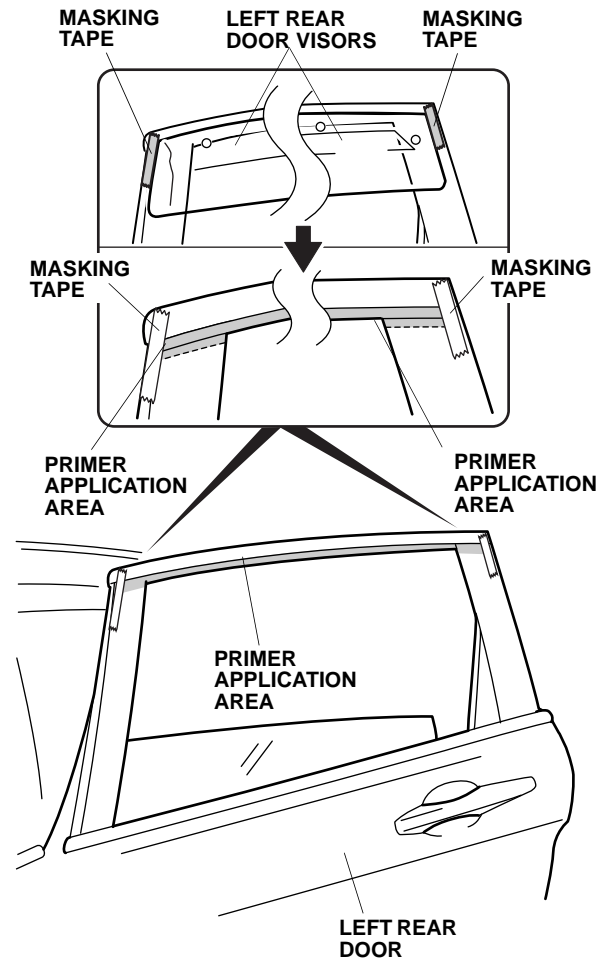

- Using isopropyl alcohol on a shop towel, clean the door sash trim where the left rear door visor will attach. Apply primer to the areas shown.
 - Wipe up any excess primer immediately.
 - Wait at least 3 minutes or more to cure the primer before proceeding.

- Attach a piece of masking tape to the end of each of the two adhesive backings on the inside of the left rear door visor. Peel back the adhesive backings and tape them to the front surface side of the door visor. Remove all the other remaining adhesive backings.

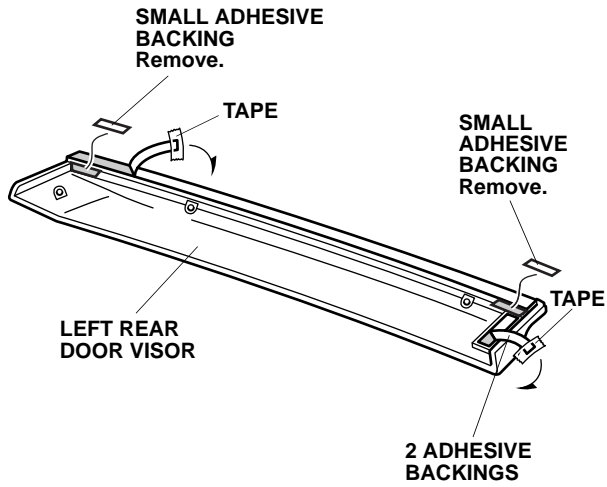

- Remove the masking tape you attached in step 4.

- Reinstall the left rear door visor (three clips). Make sure there is no clearance between the bracket and door sash trim.

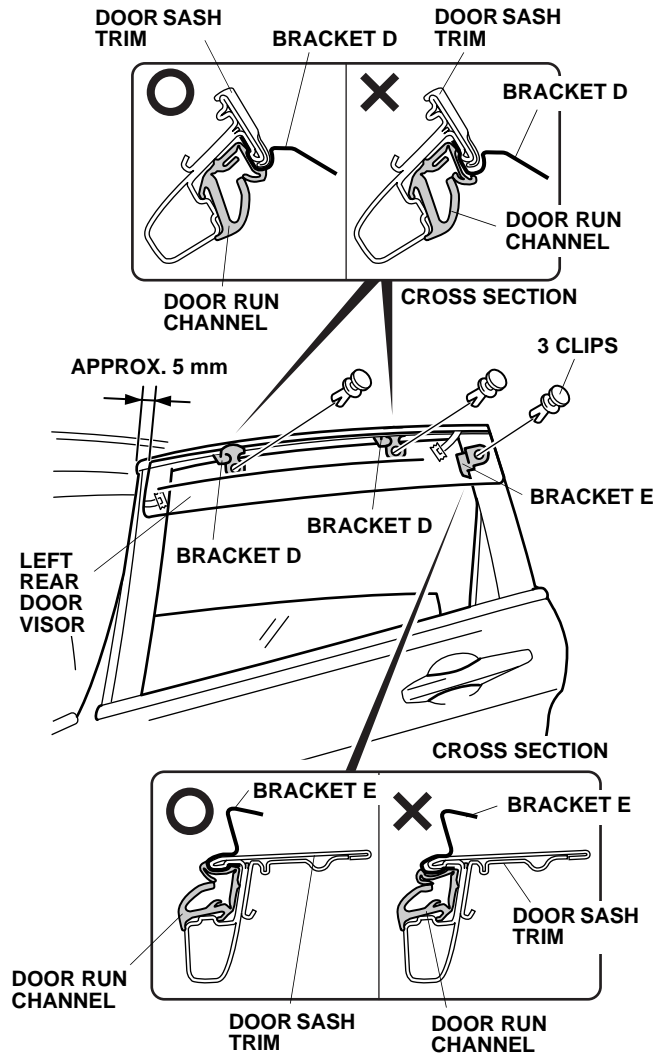

9. Using the palm of your hand, press down on the left rear door visor while removing the two adhesive backings. Make sure there is no clearance between the bracket and door sash trim.

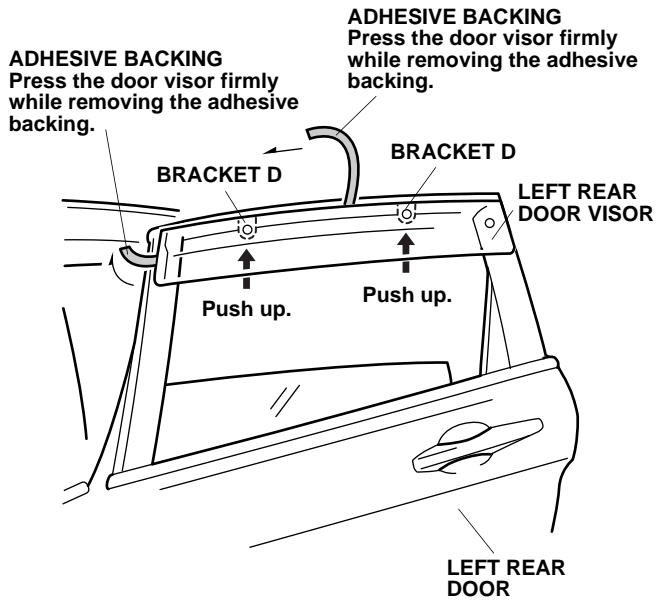

10. Repeat 1 thru 9 to install the right rear door visor.

Installing the Front Door Visors

11. Fully open the left front door window.
12. Install the two brackets D on the door sash trim in the positions shown.
 - Check the shape of each bracket and install them in the correct positions.
 - Check that the door run channel is installed properly.

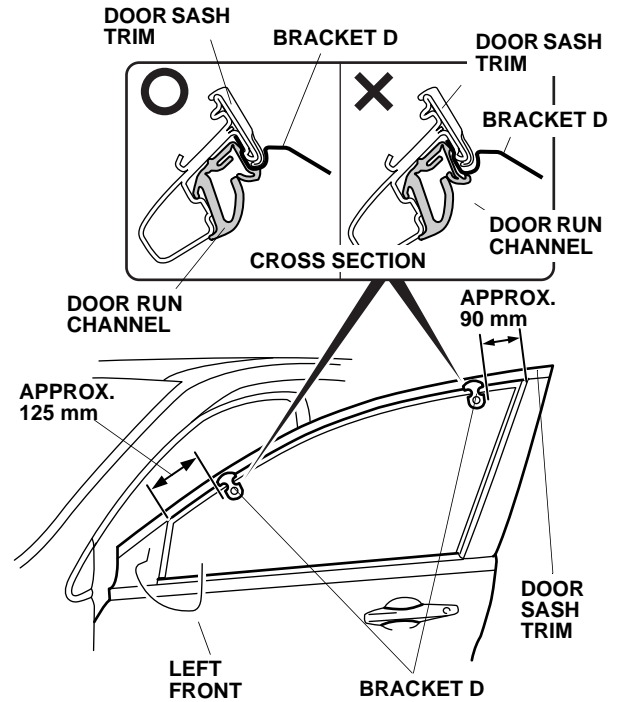

13. Install bracket A on the door sash trim.

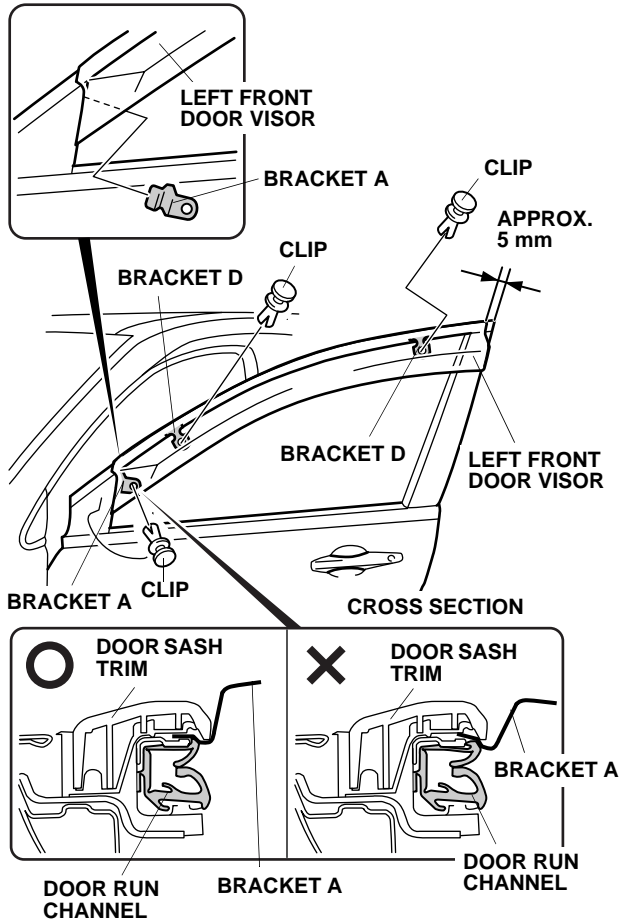

14. Position the left front door visor on the door sash by hooking the front bracket of the door visor on the door sash. Adjust the positions of bracket A and brackets D and install the three clips. Make sure there is no clearance between the bracket and door sash trim.

15. Attach masking tape to the door sash at the ends of the left front door visor, then remove the door visor (three clips).

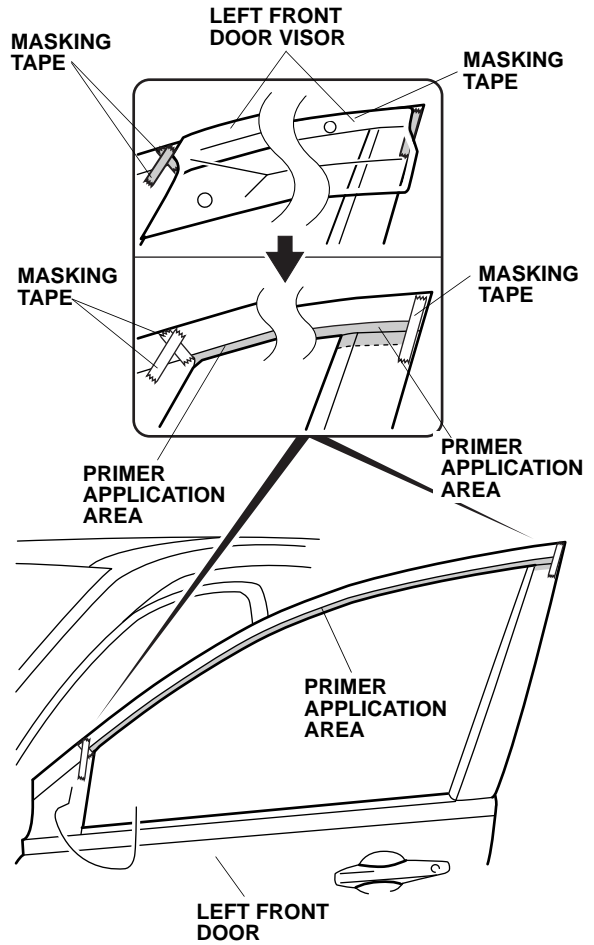

16. Using the isopropyl alcohol on a shop towel, clean the door sash trim where the left front door visor will attach. Apply primer to the areas shown.
- Wipe up any excess primer immediately.
 - Wait at least 3 minutes or more to cure the primer before proceeding.

17. Attach a piece of masking tape to an end of each of the two adhesive backings on the inside of the left front door visor. Peel back the adhesive backings and tape them to the front surface side of the door visor. Remove all the remaining adhesive backings.

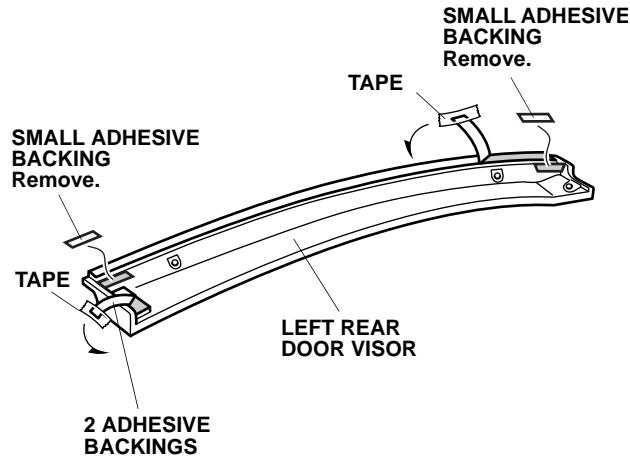

18. Remove the masking tape you attached in step 15.

19. Reinstall the left front door visor (three clips). Make sure there is no clearance between the bracket and door sash trim.

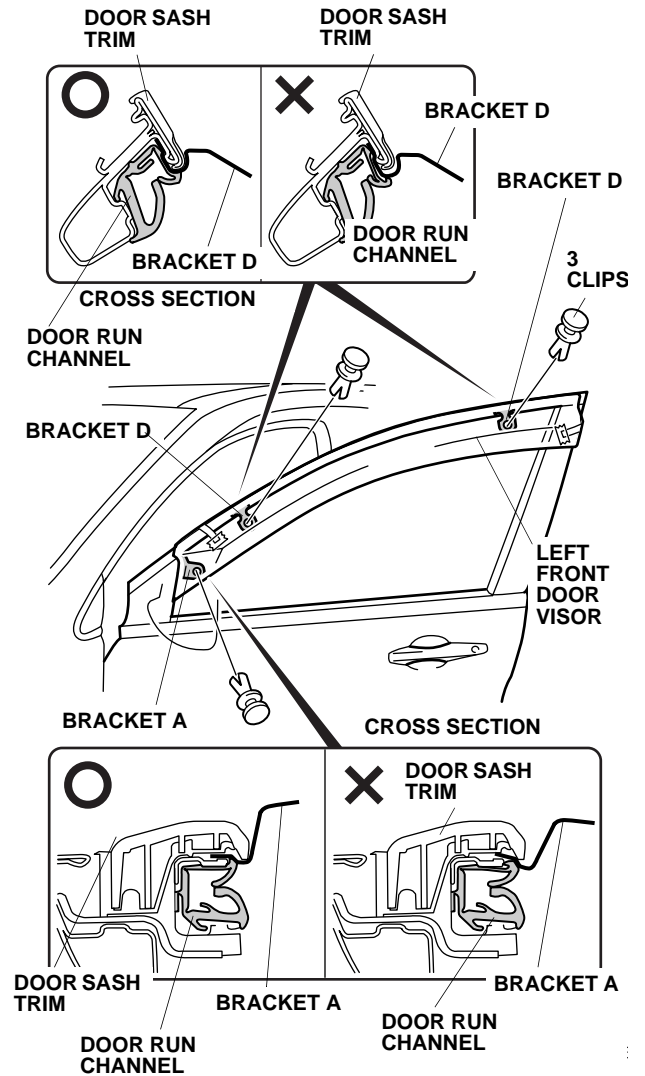

- Using the palm of your hand, press down on the left front door visor while removing the two adhesive backings. Make sure there is no clearance between the bracket and door sash trim.

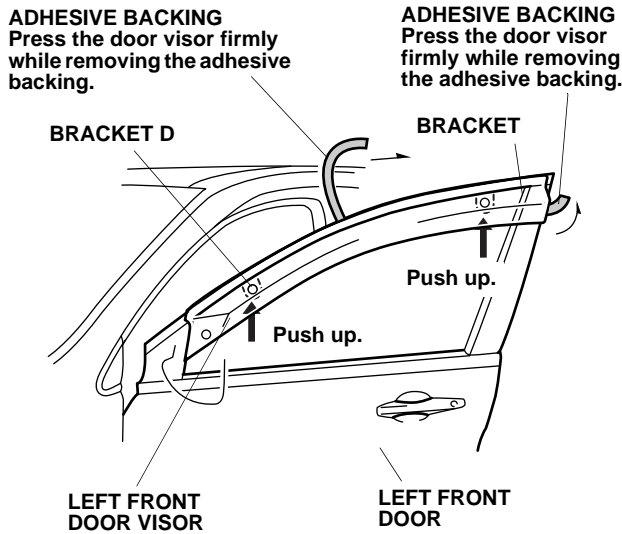

- Using scissors, cut the EPT sealer in half.
- Remove bracket A (one clip).

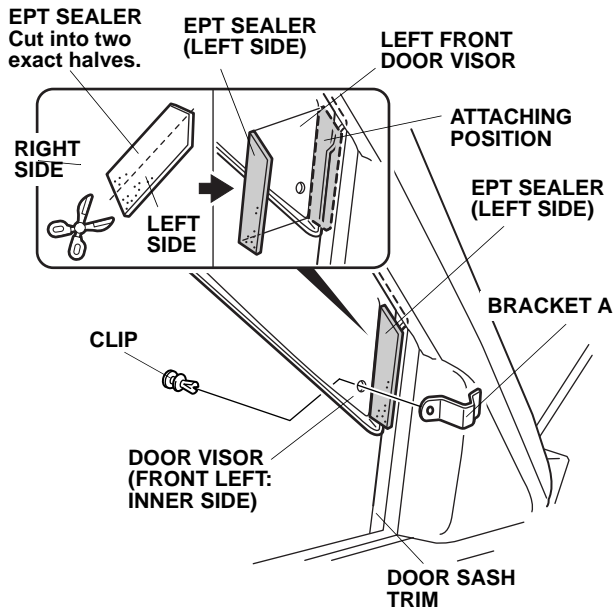

- Using isopropyl alcohol on a shop towel, clean the area where the EPT sealer will attach.
- Attach the EPT sealer in the area shown, and reinstall the bracket A.
- Repeat steps 11 thru 24 to install the right door visor.
- Raise and lower all the windows several times to seat the glass run channels.

USE AND CARE

- To clean the door visor, wipe it with a soft cloth dampened with clean water.
- To remove dust and dirt, clean with a soft cloth dampened with a mild detergent and water solution. Never use organic solvents such as thinner, benzene, alcohol, etc., or cleaners containing abrasive compounds.