



INSTALLATION INSTRUCTIONS

Accessory
STEERING WHEEL TRIM

Application
2009 ACCORD
4-DOOR

Publications No.
All 40008
Issue Date
JULY 2008

PARTS LIST

Steering Wheel Trim (Without Navigation) P/N 08Z13-TA0-100

Right steering wheel trim

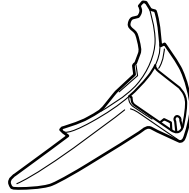

Left steering wheel trim

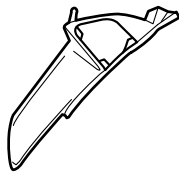

2 Torx bolts



Steering Wheel Trim (With Navigation) P/N 08Z13-TA0-100A

Right steering wheel trim

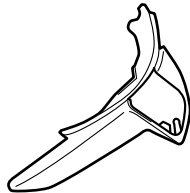

Left steering wheel trim

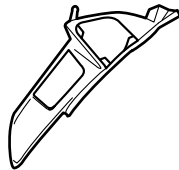

2 Torx bolts



TOOLS REQUIRED

Phillips screwdriver
Flat-tip screwdriver
14 mm T-handle wrench
Torque wrench
14 mm Socket wrench
Steering wheel puller
T30 Torx bit

INSTALLATION

Customer Information: The information in this installation instruction is intended for use only by skilled technicians who have the proper tools, equipment, and training to correctly and safely add equipment to your vehicle. These procedures should not be attempted by "do-it-yourselfers."

NOTE:

- Observe all safety notes and precautions described in the service manual in addition to these described in this installation instruction.
- After installing the steering wheel, you must align the steering wheel spoke angle to the straight-ahead position by adjusting the front toe.
 1. Make sure you have the anti-theft codes for the radio and navigation system (if equipped), then write down the radio presets.
 2. Disconnect the negative cable from the battery, and wait for at least 3 minutes before you start to install the steering wheel trim.

- From under the driver's side airbag, pry up on the four retaining tabs, and remove the access panel.

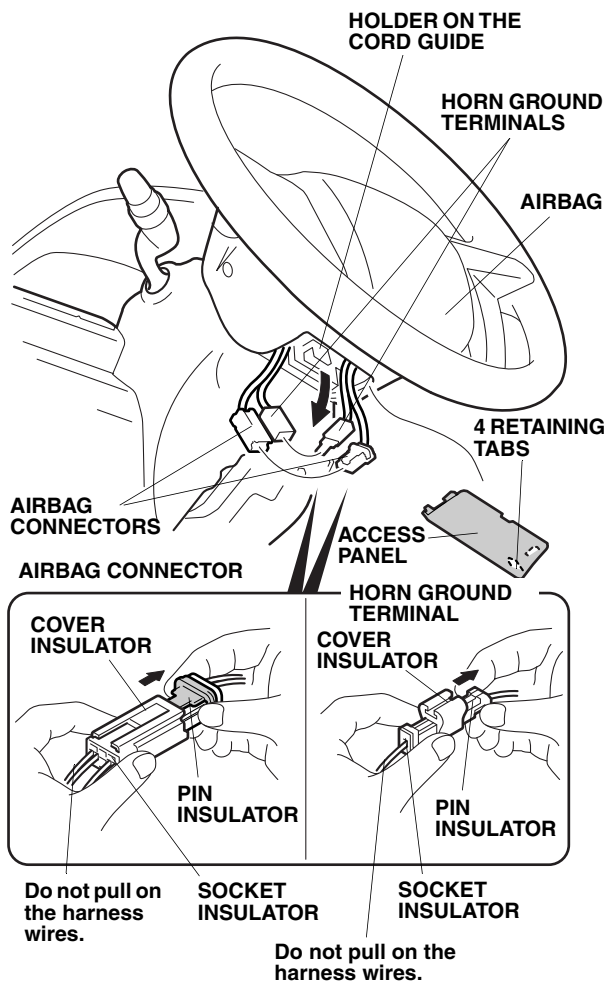

- Remove the horn ground terminal and the airbag connectors from the holder on the cord guide. Unplug the horn ground terminals and the airbag connectors.
- While holding the pin insulator, pull out on the cover insulator. Do not pull on the socket insulator and harness wires.

- Remove and discard the two Torx bolts that secure the airbag, and remove the airbag. Carefully set the airbag in a secure location with the pad facing up. Do not drop or bump the airbag against anything.

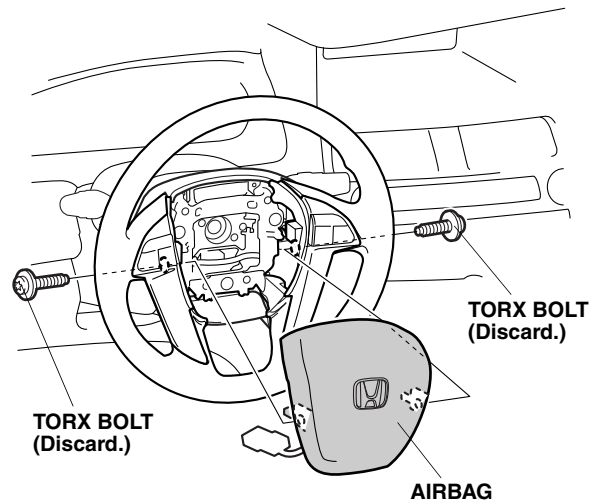

7. Turn the steering wheel so the front wheels are in the straight-ahead position.
8. Remove the steering wheel bolt. Disconnect the vehicle 20-pin connector from the cable reel. Using a steering wheel puller, remove the steering wheel. Do not thread the steering wheel puller bolts in more than 10 mm. Be careful not to move the steering wheel during removal.

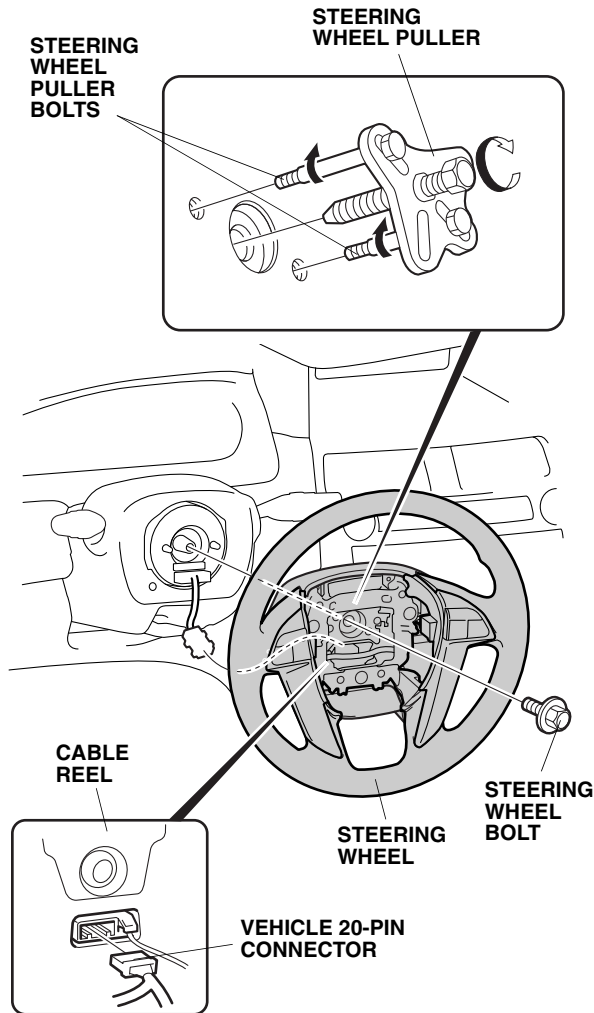

9. Loosen the two self-tapping screws from the steering wheel.

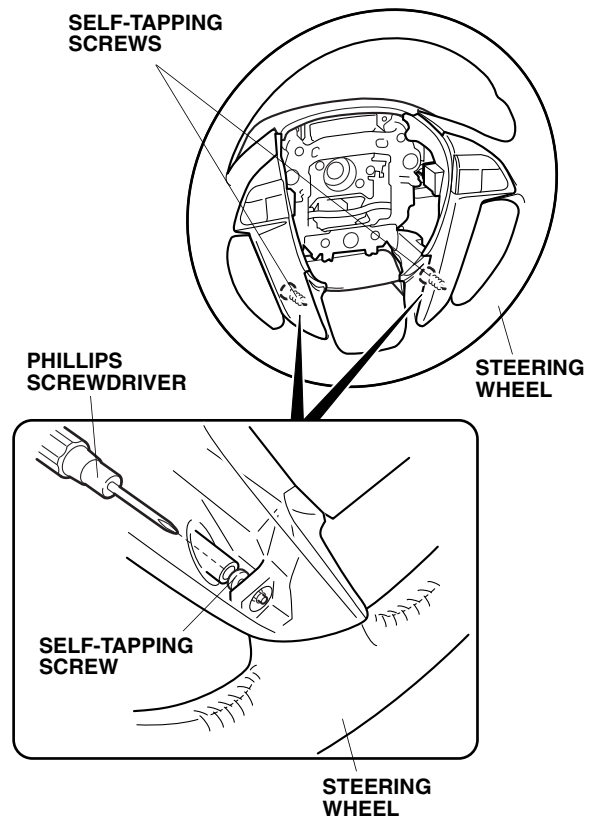

10. Remove the self-tapping screw that fastens the left steering wheel trim and the right steering wheel trim from the steering wheel, and unplug the switch connectors.

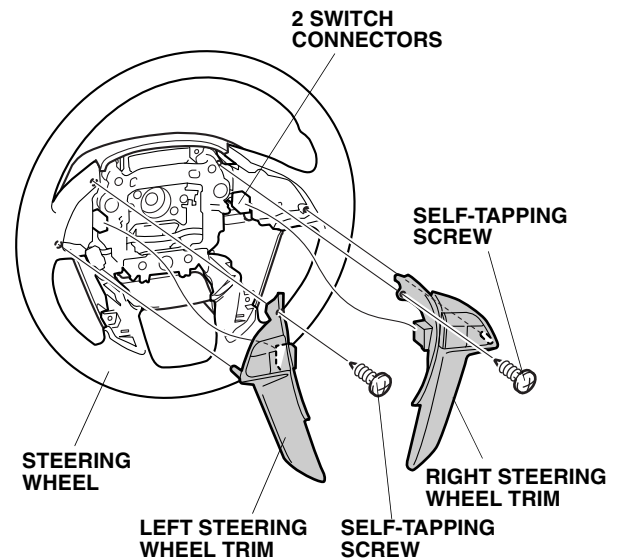

11. Remove the left steering wheel trim and right steering wheel trim from the steering wheel.

For vehicles without a NAVI switch continue with step 12.
For vehicles with a NAVI switch, go to step 14.

Without NAVI Switch

12. Remove the four screws that fasten the two switches from the left steering wheel trim and right steering wheel trim, release the retaining tabs, and remove the two switches.

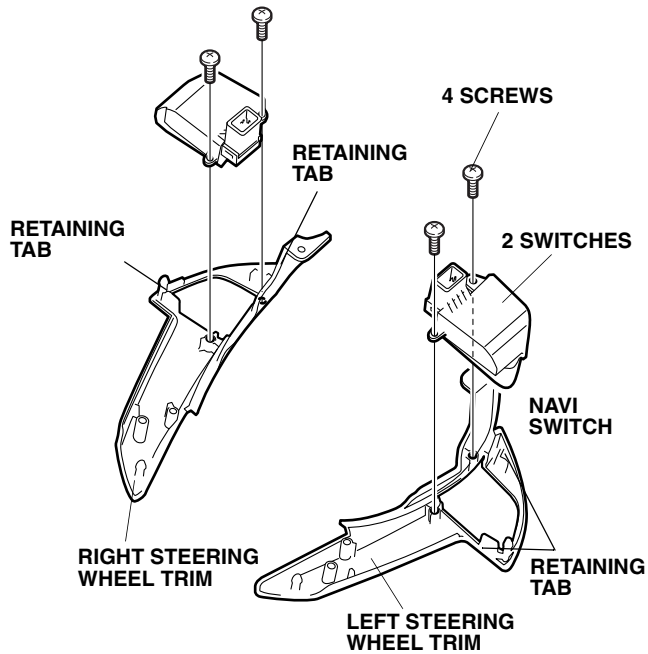

13. Install the two switches to the new left steering wheel trim and new right steering wheel trim with the four screws (reuse). Make sure the retaining tabs are engaged. Go to step 16.

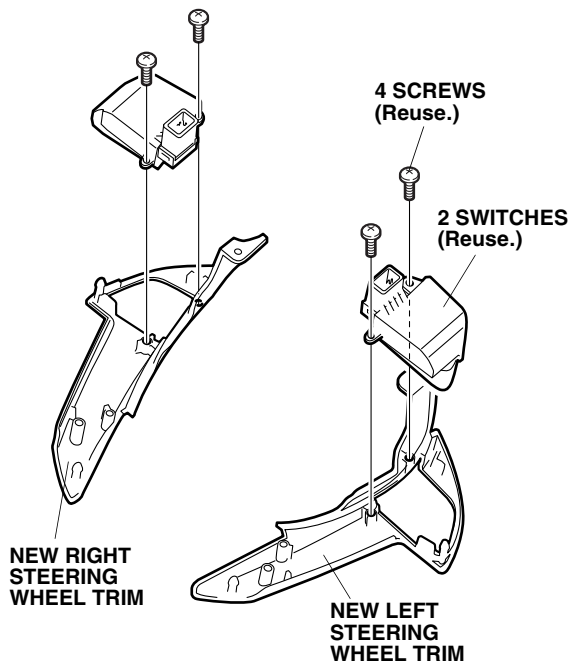

With NAVI Switch

14. Remove the five screws that fasten the two switches and NAVI switch from the left steering wheel trim and right steering wheel trim, release the retaining tab, and remove the two switches and NAVI switch.

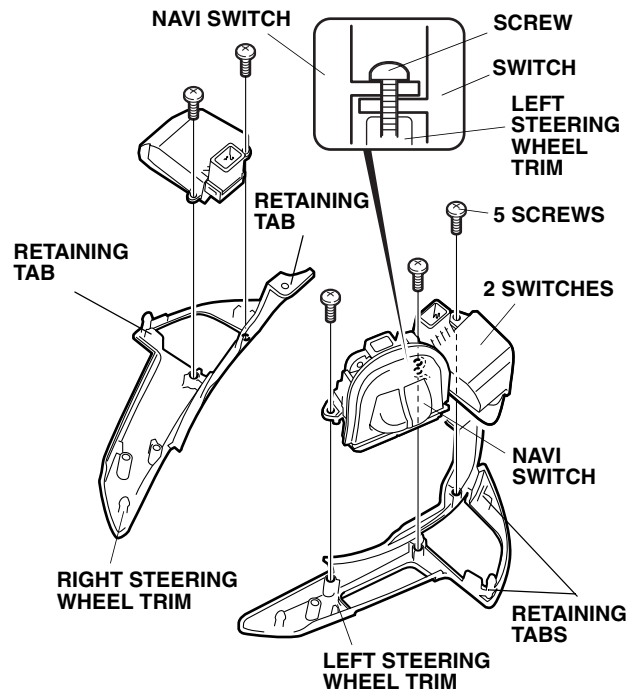

15. Install the two switches and NAVI switch to the new left steering wheel trim and new right steering wheel trim with the five screws (reuse). Make sure the retaining tabs are engaged.

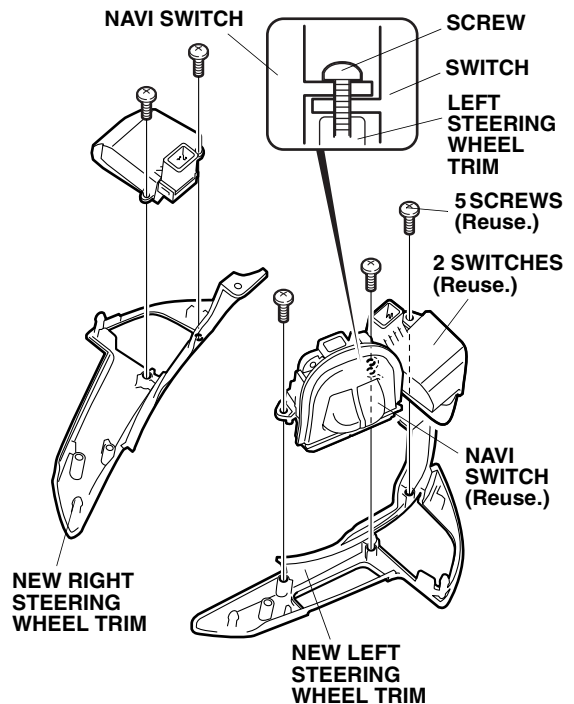

16. Connect each switch connector and install each new steering wheel trim to the steering wheel with the two screws you removed.

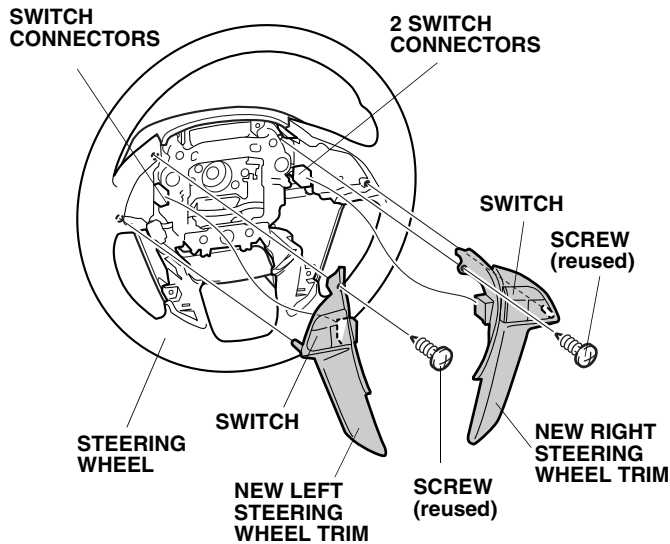

17. Reinstall the two self-tapping screws to the steering wheel.

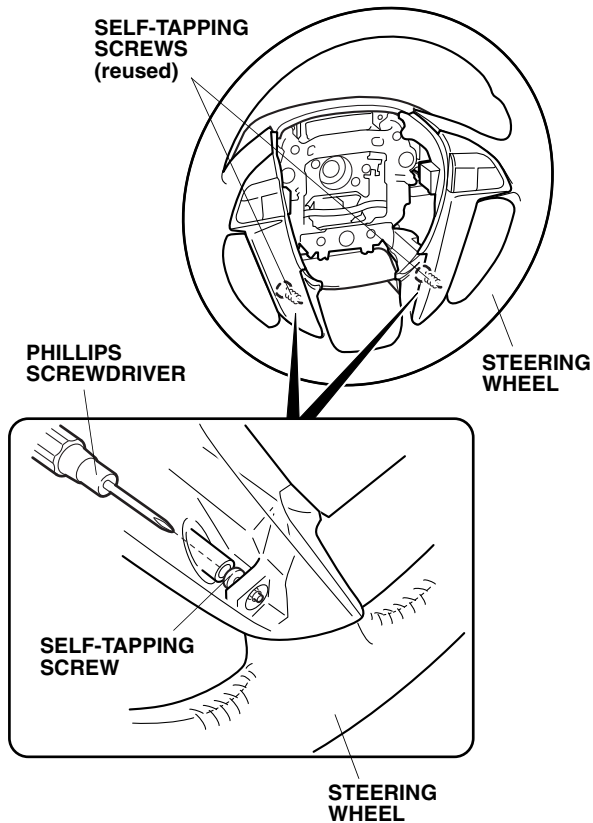

If the cable reel was moved, continue with step 18; if it was not moved, go to step 19.

18. Align the cable reel:

- Rotate the cable reel clockwise all the way until it stops.
- Turn the cable reel counterclockwise about three complete turns until the "TOP" arrow on the cable reel points up.

19. Install the steering wheel on the steering column shaft in the straight-ahead position:

- Route the wire harness through the opening in the steering wheel.
- Align the two tabs of the cancelling sleeve with the two cutouts in the steering wheel as shown.
- Check that the wire harness are not pinched.

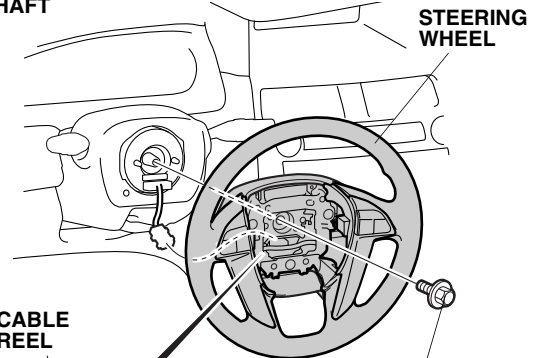
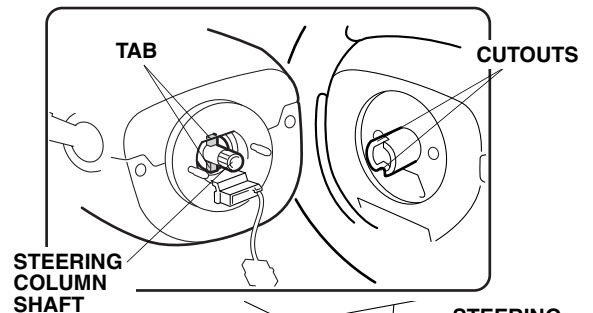

CABLE REEL



VEHICLE 20-PIN CONNECTOR

STEERING WHEEL BOLT (reused)
Torque to 49 N·m
(36 lb-ft)

20. Install the steering wheel bolt. Torque the steering wheel bolt to 49 N·m (36 lb-ft).

21. Reconnect the 20-pin connectors.

22. Get the airbag, and route the airbag harness and horn harness down through the steering wheel. Position the airbag on the steering wheel, and check that the wire harness are not pinched. Install the two new Torx bolts supplied. Torque the Torx bolts to 10 N·m (7.3 lb-ft).

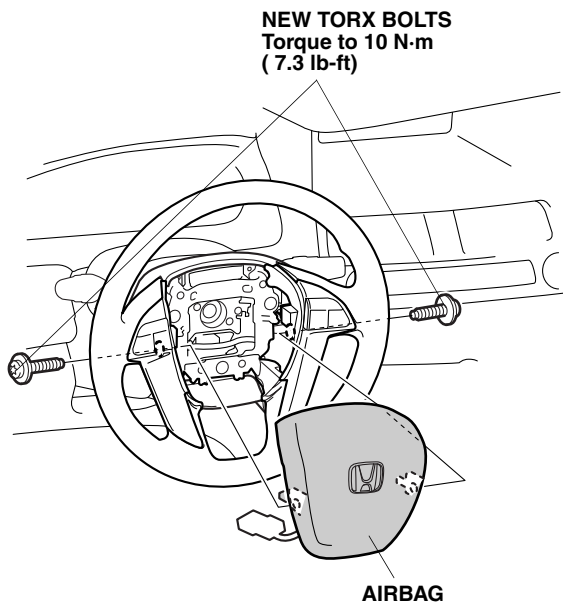

23. From under the steering wheel, connect the horn ground terminals, and attach the terminals to the back of the switch plate.

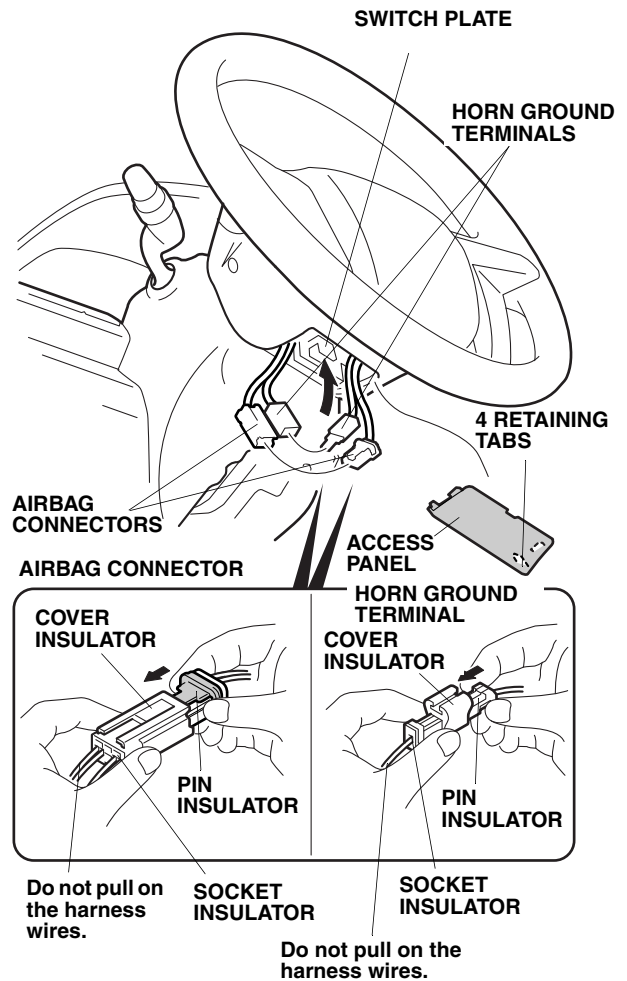

24. Connect the airbag harness connectors:
- Push the socket insulator onto the pin insulator until it contacts the tab on the pin insulator.
 - Do not push the socket insulator onto the pin insulator by pushing on the cover insulator.
 - Continue pushing on the socket insulator in the same direction until the cover insulator rides over the tab on the pin insulator and is locked securely.
 - Reinstall the airbag harness connectors to the holder on the cord guide.
 - Reinstall the access panel.

25. Reconnect the negative cable to the battery.
26. Make sure the steering wheel is in the straight-ahead position with the front wheels. If the spoke angle of the steering wheel is not in the straight-ahead position with the front wheels, adjust the front toe as described in the service manual.
27. Verify that the horn works.
28. Turn the ignition key on, and verify that the SRS warning light comes on and stays on for 6 seconds; turn the key off to make sure the SRS indicator goes off.
29. Enter the anti-theft code for the radio and the navigation system (if equipped), then reset the customer's radio presets.
30. Reset the clock on models without navigation.